



vision
trimline



WELCOME

Welcome to the Vision Trimline range, our innovative fires are skilfully engineered to allow a trimless aspect. This means no distracting frames or visible mechanical workings - just fire. All our appliances are available in natural gas and LPG and the prices listed are suggested selling prices including VAT.

INTERIOR STYLING & FUEL BED OPTIONS	4
TL55XH	6
TL64	6
TL73H	7
TL83	8
TL100	8 - 9
TL120	9
TL140	10
TL170H	11
GEMSTONE COLLECTION	11
CONCENTRIC FLUE	14 - 19

EVERYTHING YOU NEED IN ONE PACKAGE

We know the importance of keeping things simple. That's why every Vision Trimline fire comes complete with 'included extras' to help make your purchase as easy as possible.

As standard, all inset fires come complete with:

- Ecomax remote control
- Adjustable legs
- Control access door
- Convection vents
- Glowing embers
- Double Burner (DB) feature



INTERIOR STYLING

For that extra WOW factor, why not choose to upgrade to a black mirrored glass lining for your fire chamber and add a reflection to the fuel bed and flames to give a remarkable effect of added depth and detail.

If burning logs is not the look you are going for, then perhaps you would be more interested in an alternative fuel bed for your fire. The collection features a range of stunning options to choose from.

Lamel Interior



Black Groove Interior



Vermiculite Interior



Interior Grey Brick



Black Glass Interior



Fire Brick Interior



Reeded Panel



FUEL BED OPTIONS

High Definition Logs



Carrara Stones



White Pebbles



Basalt



TL55XH

PRODUCT	ARG	PRICE
TL55XH FRONT WITH LAMEL INTERIOR	£6399	£5899
TL55XH TUNNEL WITH LAMEL INTERIOR	£6999	£6399
OPTIONAL EXTRAS		
WIFI KIT		+£399
REMOTE CONTROL WALL MOUNT		+£49
MAINS ADAPTOR		+£99
FUEL BED OPTIONS		
LED BURNER		+£399

TL64

PRODUCT	ARG	PRICE
TL64 FRONT WITH ANTHRACITE STEEL INTERIOR	£5299	£4899
TL64 PANORAMIC WITH ANTHRACITE STEEL INTERIOR	£5999	£5499
TL64 CORNER (LEFT OR RIGHT) WITH ANTHRACITE STEEL INTERIOR	£5799	£5199
OPTIONAL EXTRAS		
WIFI KIT		+£399
REMOTE CONTROL HOLDER		+£49
MAINS ADAPTOR		+£99
WALL BRACKET		+£149
WIDE TRIMS FOR FRONT		+£217.80
WIDE TRIMS FOR PANORAMIC		+£358.80
WIDE TRIMS FOR CORNER (LEFT OR RIGHT)		+£298.80
FUEL BED OPTIONS		
LED GLOWING FUEL BED		+£499
INTERIOR OPTIONS		
BLACK GLASS		+£799
INTERIOR GREY BRICK		+£499
REEDED PANEL		+£399

TL73H

PRODUCT	ARG	PRICE
TL73H FRONT WITH ANTHRACITE STEEL INTERIOR	£4699	£3999
TL73 TUNNEL WITH ANTHRACITE STEEL INTERIOR	£5799	£4899
TL73 ROOM DIVIDER WITH ANTHRACITE STEEL INTERIOR	£4999	£4599
OPTIONAL EXTRAS		
WIFI KIT		+£399
REMOTE CONTROL HOLDER		+£49
MAINS ADAPTOR		+£99
WIDE TRIMS FOR FRONT/H/TUNNEL		+£217.80
WIDE TRIMS FOR ROOM DIVIDER		+£295.02
FUEL BED OPTIONS		
PEBBLES		+£399
INTERIOR OPTIONS (TL73H ONLY)		
LAMEL		+£199
VERMICULITE		+£249
FIRE BRICK		+£599
BLACK GLASS		+£749
SLIP SETS TO SUIT		
BRUSHED STEEL & GRANITE		+£199
POLISHED GRANITE		+£199
HONED GRANITE		+£199
AGEAN LIMESTONE		+£199
NATURAL SLATE & GRANITE		+£199
PORTUGUESE LIMESTONE		+£199

TL83

PRODUCT	ARG	PRICE
TL83 FRONT WITH ANTHRACITE STEEL INTERIOR	£5199	£4799
TL83 PANORAMIC WITH ANTHRACITE STEEL INTERIOR	£5799	£4999
TL83 CORNER (LEFT OR RIGHT) WITH ANTHRACITE STEEL INTERIOR	£5599	£4999
TL83 TUNNEL WITH ANTHRACITE STEEL INTERIOR	£7399	£6899
TL83 ROOM DIVIDER WITH ANTHRACITE STEEL INTERIOR	£7199	£6399
OPTIONAL EXTRAS		
WIFI KIT		+£399
REMOTE CONTROL HOLDER		+£49
MAINS ADAPTOR		+£99
FUEL BED OPTIONS		
LED GLOWING FUEL BED		+£399
INTERIOR OPTIONS		
BLACK GLASS		+£799
INTERIOR GREY BRICK (NOT AVAILABLE ON TL83 ROOM DIVIDER)		+£699
BLACK GROOVE		+£599

TL100

PRODUCT	ARG	PRICE
TL100 FRONT WITH LAMEL INTERIOR (NAT GAS)	£4299	£3749
TL100 FRONT WITH LAMEL INTERIOR (LPG)	£4999	£4399
TL100 PANORAMIC WITH LAMEL INTERIOR	£4999	£4499
TL100 CORNER (LEFT OR RIGHT) WITH LAMEL INTERIOR	£4949	£4399
TL100 TUNNEL WITH ANTHRACITE INTERIOR	£4999	£4299
OPTIONAL EXTRAS		
WIFI KIT		+£300
REMOTE CONTROL HOLDER		+£49
MAINS ADAPTOR		+£99
WIDE TRIMS FOR FRONT/TUNNEL		+£235.62
WIDE TRIMS FOR PANORAMIC		+£314.82
WIDE TRIMS FOR FRONT CORNER (LEFT OR RIGHT)		+£275.22

TL100

FUEL BED OPTIONS	
PEBBLES	+£499
CARRARA	+£89
BASALT	+£89
INTERIOR OPTIONS	
BLACK GLASS FOR FRONT	+£529
BLACK GLASS FOR PANORAMIC	+£399
BLACK GLASS FOR CORNER	+£499
*BLACK GLASS NOT AVAILABLE ON TUNNEL MODELS	

TL120

PRODUCT	ARG	PRICE
TL120 FRONT WITH LAMEL INTERIOR	£5399	£4199
TL120 PANORAMIC WITH LAMEL INTERIOR	£6949	£6199
TL120 CORNER (LEFT OR RIGHT) WITH LAMEL INTERIOR	£5999	£5399
TL120 TUNNEL WITH ANTHRACITE STEEL INTERIOR	£5999	£4999
TL120 ROOM DIVIDER	£8099	£7349
OPTIONAL EXTRAS		
LED GLOWING FUEL BED (TL120 ROOM DIVIDER ONLY)		+£799
WIFI KIT		+£300
REMOTE CONTROL HOLDER		+£49
MAINS ADAPTOR		+£99
WIDE TRIMS FOR FRONT/TUNNEL		+£267.30
WIDE TRIMS FOR PANORAMIC		+£334.62
WIDE TRIMS FOR FRONT CORNER (LEFT OR RIGHT)		+£314.82
FUEL BED OPTIONS		
PEBBLES		+£499
CARRARA		+£119
BASALT		+£119
INTERIOR OPTIONS		
BLACK GLASS FOR FRONT		+£599
BLACK GLASS FOR PANORAMIC		+£479
BLACK GLASS FOR CORNER		+£549
*BLACK GLASS NOT AVAILABLE ON TUNNEL MODELS		

TL140

PRODUCT	ARG	PRICE
TL140 FRONT WITH LAMEL INTERIOR	£5999	£5199
TL140 PANORAMIC WITH LAMEL INTERIOR	£6659	£5999
TL140 CORNER (LEFT OR RIGHT) WITH LAMEL INTERIOR	£6599	£5999
TL140 TUNNEL WITH ANTHRACITE STEEL INTERIOR	£6999	£6399
OPTIONAL EXTRAS		
WIFI KIT		+£399
REMOTE CONTROL HOLDER		+£49
OPTIONAL EXTRAS CONTINUED		
MAINS ADAPTOR		+£99
WIDE TRIMS FOR FRONT/TUNNEL		+£295.02
WIDE TRIMS PANORAMIC		+£354.42
WIDE TRIMS FOR FRONT CORNER (LEFT OR RIGHT)		+£334.62
FUEL BED OPTIONS		
PEBBLES		+£499
CARRARA		+£119
BASALT		+£119
INTERIOR OPTIONS		
BLACK GLASS FOR FRONT		+£629
BLACK GLASS FOR PANORAMIC		+£499
BLACK GLASS FOR CORNER		+£599

*BLACK GLASS NOT AVAILABLE ON TUNNEL MODELS

TL170H

PRODUCT	ARG	PRICE
TL170H FRONT WITH LAMEL INTERIOR	£6399	£5899
OPTIONAL EXTRAS		
WIFI KIT		+£399
REMOTE CONTROL HOLDER		+£49
MAINS ADAPTOR		+£99
WIDE TRIMS FOR FRONT		+£267.30
FUEL BED OPTIONS		
PEBBLES		+£599
FUEL BED OPTIONS CONTINUED		ARG PRICE
CARRARA		+£129
BASALT		+£129
INTERIOR OPTIONS		
BLACK GLASS		+£749

GEMSTONE COLLECTION

PRODUCT	ARG	PRICE
TOURMALINE WITH ANTHRACITE STEEL INTERIOR	£4299	£3999
OPAL WITH ANTHRACITE STEEL INTERIOR	N/A	£5499
TOPAZ WITH ANTHRACITE STEEL INTERIOR	£5199	£4699
OPTIONAL EXTRAS		
WIFI KIT		+£399
OPTIONAL EXTRAS CONTINUED		
REMOTE CONTROL HOLDER		+£49
MAINS ADAPTOR		+£99
WOOD STOOL		+£499
FIRE STOOL		+£499
FUEL BED OPTIONS		
LED FUEL BED FOR TOURMALINE/TOPAZ/OBSIDIAN		+£424



CONCENTRIC FLUE SYSTEMS

Our concentric flue systems manufactured in the Netherlands by Holetherm are specifically designed for use with balanced flue gas fires.

We have a wide range of flue components and sizes to suit most configurations. Quick and easy to install our concentric flue is made from stainless steel and is fully weatherproof. Our concentric flue systems are backed by a 10 year conditional warranty*.

* Terms & Conditions apply



UP AND OUT PACKAGES

Code	Description	SSP Inc. vat
0128047	TC Flue Pack 1 (up & out) 38 & 46 Only	£356.90
0128048	TC Flue Pack 2 (up & out) 100 & 150 Only	£485.10
0128049	TC Flue Pack 3 (up & out) 130 & 200 Only	£726.50

STRAIGHT LENGTHS

Available in three lengths which can be easily combined to achieve the required height for the installation. Each joint is firmly secured using the locking bands supplied.

Code	Description	Size	Dia A	Dia B	L1	SSP Inc. vat
0127800	Length 1000mm	100/150	100	150	1000	£125.89
0127900	Length 1000mm	130/200	130	200	1000	£160.54
0127801	Length 500mm	100/150	100	150	500	£102.80
0127901	Length 500mm	130/200	130	200	500	£114.35
0127803	Length 250mm	100/150	100	150	250	£91.24
0127903	Length 250mm	130/200	130	200	250	£102.80

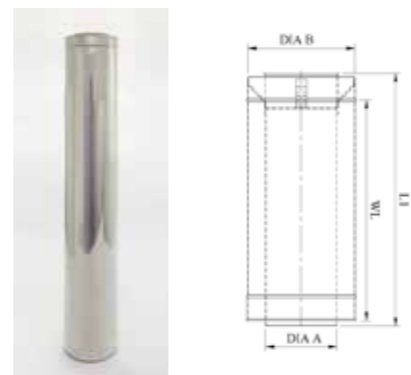

APPLIANCE ADAPTOR

Code	Description	SSP Inc. vat
0127814	Balanced Flue Adaptor Appliance 100/150	£53.89
0127914	Balanced Flue Adaptor Appliance 130/200	£64.91

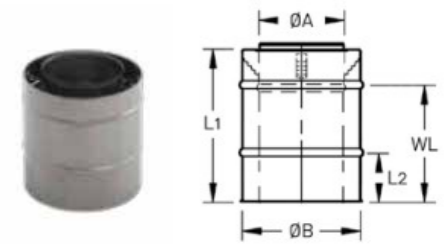

ADJUSTABLE LENGTHS

This component is used to ensure any variation in length is achievable as outlined below. The adjustable lengths are non-load bearing and telescopic and a wall bracket must be used on the component directly above the chimney run. Extra insulation is included so that additional length can be filled.

Adjustable length 310 - 445mm

Code	Description	Size	Dia A	Dia B	L1	SSP Inc. vat
0127804	Adjustable Length	100/150	100	150	310-445	£114.35
0127904	Adjustable Length	130/200	130	200	310-445	£137.45



INSPECTION LENGTHS

Code	Description	Size	Dia A	Dia B	SSP Inc. vat
0127845	Inspection Length	100/150	100	150	£125.89
0127945	Inspection Length	130/200	130	200	148.99

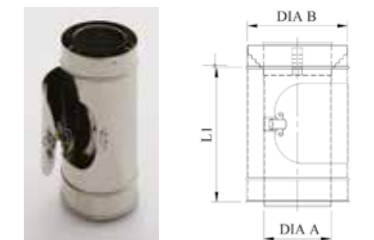

ELBOWS

Available in four options and are used when a change in direction of a flue run is required. They can be easily rotated where required to achieve the required direction.

Code	Description	Size	Dia A	Dia B	L1	L2	SSP Inc. vat
0127808	Elbow 15°	100/150	100	150	72	42	£127.06
0127908	Elbow 15°	130/200	130	200	90	52	£167.47
0127805	Elbow 30°	100/150	100	150	72	42	£127.06
0127905	Elbow 30°	130/200	130	200	90	52	£167.47
0127806	Elbow 45°	100/150	100	150	72	42	£127.06
0127906	Elbow 45°	130/200	130	200	90	52	£167.47
0127807	Elbow 90°	100/150	100	150	72	90	£150.14
0127907	Elbow 90°	130/200	130	200	87	106	£167.47



Pictured above is the 30° elbow

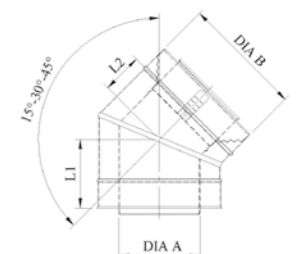

INSPECTION ELBOWS

Code	Description	Size	Dia A	Dia B	L1	L2	L3	L4	L5	SSP Inc. vat
01278071	Inspection Elbow	100/150	100	150	72	90	44	145	150	£229.84
01279071	Inspection Elbow	130/200	130	200	87	106	69	177	177	£248.33

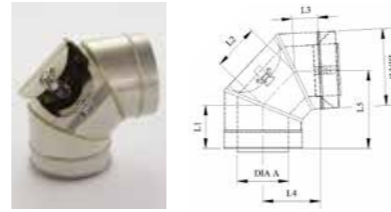

WALL BAND

The wall band is used to support the flue system off of the wall.

Code	Description	Size	Dia A	Dia B	L1	L2	L3	SSP Inc. Vat
01278171	Wall Band	100/150	150	208	208	120-175	40	£40.43
01279171	Wall Band	130/200	200	206	206	148-203	40	£45.05

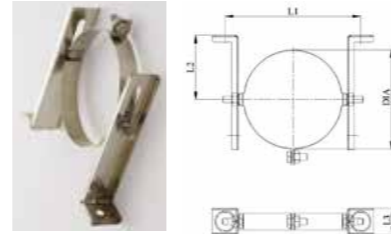

FLASHINGS

Flashings are used to form a watertight seal when the chimney penetrates a slate tiled roof available in lead or aluminium bases in a variety of sizes.

Code	Description	Size	Dia	L1	L2	SSP Inc. Vat
01278221	Lead Roof Flashing 20-45°	100/150	160	150	700x800	£148.99
01279221	Lead Roof Flashing 20-45°	130/200	210	150	700x800	£195.19

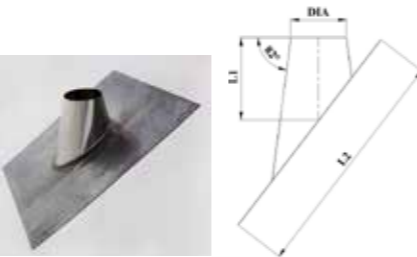

Code	Description	Size	Dia	L1	L2	SSP Inc. Vat
01278231	Roof Flashing 0-10°	100/150	160	190	550x500	£79.69
01279231	Roof Flashing 0-10°	130/200	210	190	600x600	£79.69

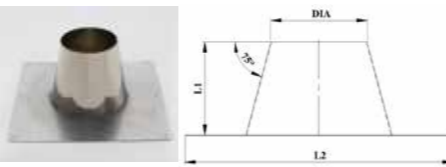

Code	Description	Size	Dia	L1	L2	SSP Inc. Vat
01278241	Roof Flashing Pitched 5-25°	100/150	160	150	550x550	£102.80
01279241	Roof Flashing Pitched 5-25°	130/200	210	150	600x600	£102.80

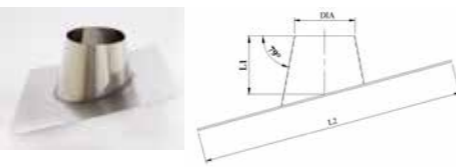

Code	Description	Size	Dia	L1	L2	SSP Inc. Vat
01278321	Lead Roof Flashing 45-60°	100/150	160	150	700x800	£160.54
01279321	Lead Roof Flashing 45-60°	130/200	210	150	700x800	£229.84

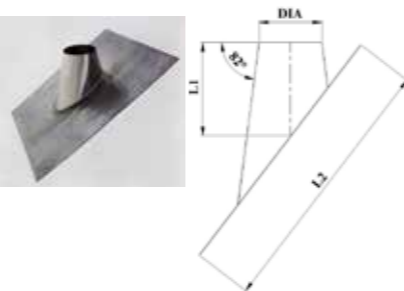

ROOF SUPPORT

Pipe support for roof intersection.

Code	Description	Size	Dia A	L1	L2	L3	L4	L5	SSP Inc. Vat
01278181	Roof Support	100/150	150	385	311	225	158	76	£39.26
01279181	Roof Support	130/200	200	514	414	300	210	101	£51.97

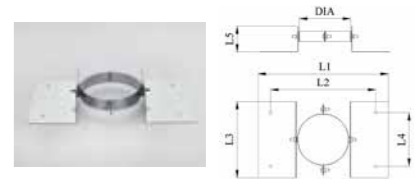

FIRESTOP PLATE

For use where flue system penetrates a wall or ceiling.

Code	Description	Size	Dia	L1	L2	SSP Inc. Vat
01278201	Firestop Plate	100/150	160	300	300	£21.94
01279201	Firestop Plate	130/200	210	350	350	£17.33

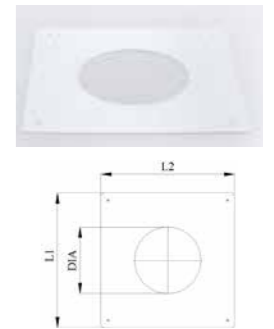

FIRESTOP PITCHED

The pitched firestop for use on vaulted ceilings where the pitch of the ceiling is between a 30-45° angle.

Code	Description	Size	L1	L2	L3	SSP Inc. Vat
01278211	Firestop Pitched	100/150	150	300	263	£21.94
01279211	Firestop Pitched	130/200	200	350	288	£23.11

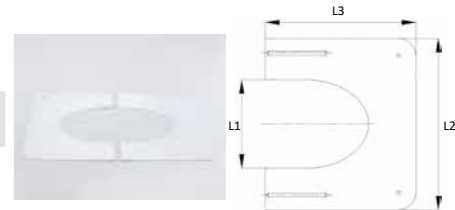

STORM COLLAR

The storm collar is fitted to the flue run just after the installation passes through the roof and is fitted to the flue run just above the roof flashing using sealant and the nuts/bolts provided to give a weatherproof seal.

Code	Description	Size	Dia A	Dia B	SSP Inc. Vat
01278161	Storm Collar	100/150	100	150	£45.05
01279161	Storm Collar	130/200	130	200	£45.05



CEILING SUPPORT

The ceiling support is supplied complete with a support collar and is for use where the flue system penetrates combustible floor.

Code	Description	Size	Dia	L1	L2	SSP Inc. Vat
01278191	Ceiling Support	100/150	150	208	40	£46.19
01279191	Ceiling Support	130/200	200	260	40	£50.83

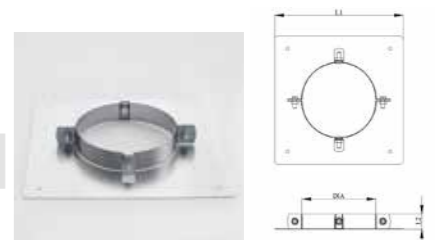

LOCKING BAND

Used to complete and secure joints.

Code	Description	Size	Dia	SSP Inc. Vat
0127828	Locking Band	100/150	145-160	£10.39
0127928	Locking Band	130/200	195-210	£21.94



GUY WIRE BAND

A guy wire bracket can be used to brace a flue system when it protrudes more than 1.5m beyond its last support. It is clamped to the flue body and allows for the fixing of guy wires to ridge stays and slate brackets.

Code	Description	Size	Dia	L1	SSP Inc. Vat
01278291	Guy Wire Band	100/150	150	25	£21.94
01279291	Guy Wire Band	130/200	200	25	£21.94

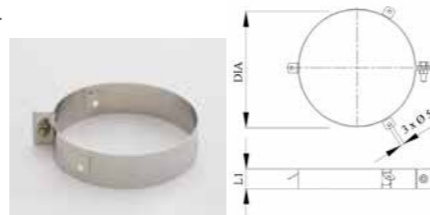

MEASURING ELEMENT

The measuring element is used for checking the chimney draught, flue temperature & combustion efficiency of the heating appliance.

Code	Description	Size	Dia A	Dia B	SSP Inc. Vat
0127891	Measuring Element	100/150	100	150	£86.89
0127991	Measuring Element	130/200	130	200	£108.90



TERMINALS

For roof and wall termination.

Code	Description	Size	Dia A	Dia B	L1	SSP Inc. Vat
0127851	Roof Terminal	100/150	100	150	502	£242.56
0127951	Roof Terminal	130/200	130	200	502	£345.35

Code	Description	Size	Dia A	Dia B	L1	L2	L3	SSP Inc. Vat
0127853	Wall Terminal	100/150	100	150	480	206	315	£206.75
0127953	Wall Terminal	130/200	130	200	495	195	400	£403.09

Code	Description	Size	SSP Inc. Vat
0128127	TL70SL Split Terminal	100/150	£185.89



BALANCED FLUE REDUCING ADAPTOR 130-100

Allows you to reduce your outer flue diameter from 200 to 150 when the flue configuration is vertical only.

Code	Description	Size	SSP Inc. Vat
0127990	Balanced Flue Reducing Adaptor	130-100	£183.65



BALANCED FLUE RENOVATION KIT

Designed for existing brick or ceramic chimneys including roof terminal.

Code	Description	Size	SSP Inc. Vat
0128040	Balanced Flue Renovation Kit 100mm C/W Terminal (Bundle)	100/150	£534.20
0127855	Balanced Flue Renovation Kit	-	£242.56



BALANCED FLUE RENOVATION KIT

Designed for existing brick or ceramic chimneys including roof terminal.

Code	Description	Size	SSP Inc. Vat
0128194	Horizontal Renovation Kit C/W Terminal X2 Spaces X1 Elbow	100/150 - 100mm C/W Terminal	£779.63

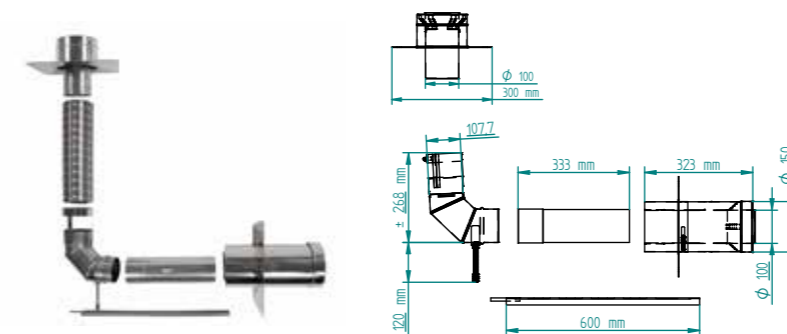

TERMS AND CONDITIONS

1. Prices

Prices charged will be those at the time of delivery as shown in our price list, or as a quotation. We reserve the right to adjust prices without prior notice. Clerical errors are subject to correction (without prior notification). In the case of items manufactured to customers own special requirements, we reserve the right to charge a deposit at the time of placing an order. Carriage paid value may vary from area to area and can be subject to change. Please contact our sales office for updated terms.

2. VAT

VAT will be charged at the rate ruling at the time of delivery.

3. Payment

Account customers payments are due by the last day of the month following delivery, unless other terms are agreed prior to dispatch. Overdue accounts: we reserve the right to suspend further deliveries until all overdue accounts are paid in full, without prior notice. Overdue accounts: we reserve the right to commence legal recovery proceedings without prior notice. COD accounts: Payment by cheque or cash to our driver on delivery of goods. COD accounts: If cheque is not available on day of delivery it must be posted to arrive at this office within seven days, failure to do so will result in your account being suspended. No more deliveries will be made until full payment is received. We reserve the right to charge interest on all outstanding invoices beyond our terms.

4. Delivery

Shortages: all shortages must be reported within 5 days of delivery of goods. Total non-delivery of goods must be reported immediately upon receipt of invoice. Any delivery days quoted are genuine forecasts but shall not be legally binding on the supplier. Timed deliveries cannot be arranged. In the event of the supplier being unable to supply goods subsequent to receiving an order from the buyer, the supplier shall not be liable for any incidental or consequential loss. It is the buyer's responsibility, regardless of delivery address, to ensure the goods are as ordered and they are of satisfactory quality. The supplier strongly recommends that the buyer checks correct description and quality on goods delivery notes. In the event of any discrepancy whatsoever, the buyer must notify the supplier within 5 days of arrival of consignment, as stated on our delivery notes, and before the goods are processed in any way otherwise no responsibility can be accepted for any claims.

Upon acceptance of deliveries the buyer must sign the suppliers or carriers delivery note. Should examination at the time of delivery not be possible, the delivery note must be signed unchecked in order for any subsequent claim to be acceptable for damage in transit. Claims for loss or damage must be made within 5 days of arrival of consignment, informing the supplier and carrier of the loss or damage involved. Damaged items and packaging must be retained for inspection. The supplier shall not be held liable otherwise. Non arrival of goods despatched from the supplier, by van or other method, must be notified to the supplier within "24 hours" from the quoted delivery date, immediately by telephone, fax or email. In all events, the limits of liability for any fault or defect in the product shall be a sum not exceeding the purchase price of the particular goods, and the supplier shall not be liable for any loss howsoever arising. The supplier will not accept any liability for delays caused by "force majeure" beyond the suppliers' control. For next day delivery on replacement glass products, we aim to deliver within 24 working hours (Mon-Fri) on all orders placed before 2pm i.e order Monday 1pm, receive glass Tuesday next day. Highland and Islands will incur higher carriage charges, prices and delivery options should be checked prior to order.

5. Claims

All claims must be in writing. Damaged goods: this must be reported as soon as it is known, but no later than 5 days after delivery. Faulty goods: in the case of claim for faulty goods, replacements may be supplied and charged, pending a report from the manufacturer. Please note: wooden mantels and decorative tiles are excluded from our 5 days policy for damaged and faulty goods, these items MUST be checked on receipt.

6. Return of goods

We cannot accept the return of goods which have been specially obtained from the manufacturer. In the case of incorrectly ordered goods, if returned, they will be subject to a re-handling charge of at least 20%. No goods will be collected by our transport without prior agreement, nor without our collection note.

7. Title & Risk

Until the supplier has been paid in full by the customer for the goods supplied by it and all other balances outstanding to it from the customer at the date such goods are invoiced to the customer have been settled:- Such goods remain the property of the supplier, although the risk therein passes to the customer as soon as the goods are delivered to the customer's premises, and the customer shall indemnify the supplier against any loss or damage thereto. Until such time as property of the goods passes to the customer, the relationship between the supplier and the customer shall be that of bailer and bailee. The customer agrees to store the goods until title to the goods shall have passed to the customer hereunder in such a way that they are readily identifiable as the property of the supplier. Without prejudice to any other remedies, the supplier may repossess those goods at any time from the customer, and for that purpose the supplier, it's agents and servants may enter any premises upon which the goods are on, or reasonably thought by the supplier to be situated. The customer has the right to agree to sell and deliver, or dispose of the goods to any sub-purchaser, but any such transaction shall be deemed to be made on behalf of the supplier (but without imposing any liability on the supplier to such sub-purchaser), and the customer shall hold the proceeds thereof, or rights arising therefrom, against the sub-purchaser for and on behalf of the supplier until such time as the customer shall have made full payment for such goods and immediately upon such sale or disposal, the property rights of the supplier hereunder shall pass to the customer on the condition that he ensures the sub-purchaser pays the purchase price into a separate bank account in the name of the customer.

Nothing in these conditions shall confer any right on the customer to return goods supplied by the supplier or refuse or delay payment thereof. In the event of a liquidator or receiver being appointed, we reserve the right to set off any monies owed to this company against any monies owed by this company. We reserve the right to pass on any costs of debt collection which may be incurred by this company. Failure to make payment of our account within our terms may result in the account being suspended, and any goods supplied thereafter will be on a pro-forma basis only.

8. Suspension or termination of any contract

If the customer shall in the sole opinion of the supplier be unable or be unlikely to be able to pay any sums he owes the supplier, then the supplier shall (without prejudice to any other rights hereunder) be entitled to demand security prior to delivery, either by payment in cash, or by bank guarantee, notwithstanding any terms previously agreed, and in the event that the customer shall be deemed to have repudiated any contract without liability. If the customer commits any breach of these terms and conditions, or of a contract, or if any distress or execution be levied upon the customer or his property, or if shall make or offer to make any arrangements with creditors or commit any act of bankruptcy, or if any petition receiving order in bankruptcy be presented or made against him, or if a receiver be appointed over all or any of the assets of the customer, or if a winding-up order be made against the customer, or if the customer goes into liquidation (otherwise than for the purpose of reconstruction or amalgamation), the supplier shall without prejudice to any other rights and remedies it might have, and without any liability whatsoever have the right forthwith by notice in writing to:

1. Suspend or terminate any contract, or any unfulfilled part thereof.
2. Stop delivery of any goods.

9. Governing Law

Any contract, and these terms and conditions, shall be governed by English law, and any disputes arising in relation to the goods supplied, or the terms of the contract, shall be determined by the English courts to whose jurisdiction and decision the supplier and the customer hereby submit.

10. Copy Invoicing

Charges for copy invoices: requests for copy invoices that are more than 90 days old will be liable to an administration fee of £1.00p.

11. Guarantee

Guarantee covers replacement faulty goods only, no consideration for consequential loss due to re-decoration or re-installation will be considered.

12. Non-internet Policy

The Penman Collection is an exclusive, non-internet range as detailed separately in the supplier/buyer contract.





vision
trimline

PRICE LIST 2025 - 2026

visionfires.co.uk

info@visionfires.co.uk

01204 868 550