



EFFORTLESS STYLE



INSTANT AMBIENCE

Featuring the iX Series with
truburn Flame Technology

SOLUS
ELECTRIC PERFECTION 2026

INTRODUCTION

INNOVATION, DESIGN & CREATIVITY	5
CONTROLS	7
SMART TECHNOLOGY	9
AMBIENT LIGHTING	11
WARRANTY	13, 95

iX SERIES

SOLUS iX COLLECTION	15
SOLUS iX TECHNICAL SPECIFICATION	17
iX10	19
iX13	23
iX15	27
iX15 SUITE	31
iX18	33
iX APPLIANCE DIMENSIONS	90 - 94
WARRANTY	13, 101

VS & VS+ COLLECTION

SOLUS VS & VS+ COLLECTION	37
SOLUS VS+ COLLECTION	39
SOLUS VS COLLECTION	43
SOLUS VS TECHNICAL SPECIFICATION	45
COPPICE LOGS	47
VS75	49
VS100	53
VS130	55
VS150	61
VS180	65
VS220	69
OPTIONAL PLINTHS, SHELVES AND SUITES	73
NIRA SUITE	75
ZENITH SUITE IN CALACATTA	77
ZENITH SUITE IN NERO	79
MALMO BENCH	81
CANOVA PLINTH IN CALACATTA	83
CANOVA PLINTH IN NERO	85
MEDIA SUITE	87
VS & VS+ DIMENSIONS	95 - 96
VS PLINTH & SHELF DIMENSIONS	97 - 100
WARRANTY	13, 101





VS150+ FRONT

INNOVATION, DESIGN & CREATIVITY.

Innovation, flair and creativity is the driving force behind Solus product development. Our design team is passionate about bringing new and exciting ideas to life by pushing the boundaries of traditional electric appliances with the amalgamation of exquisite styling, cutting edge technologies and innovation to provide instant heat, realistic flames, and adaptive ambient lighting to your living space.

The Solus range is the outstanding result of extensive research and development, meticulous attention to detail, and the highest standard of quality. With a host of unique and innovative features, these appliances are unrivalled in their class.

INSTANT HEAT AT YOUR FINGERTIPS.

Part of the Solus design ethos is to ensure that all appliances offer clear and simple controllability. Whilst functionality may have advanced and become more dynamic, we believe that intuitive interaction is paramount.

The Solus fires can be conveniently controlled in four ways:

- Manually using the multi-function panel discretely located on the appliance
- With the intuitive remote-control handset
- Through your smart device (such as phone or tablet) using Wi-Fi connectivity
- Voice Control*

With built in Wi-Fi connectivity, enhance your user experience with our smart app enabling you to control your appliance from anywhere! The app allows you to set tailored programmes, schedule on/off times, set temperatures, design custom light effects, plus much more.

The quick start heat option allows you to select low heat, high heat, or cool blow at the touch of a button. Whilst adaptive smart heating allows you to schedule the exact time and date you wish to heat your room, automatically adjusting the environment to reach and maintain the desired temperature.

*Available on iX and VS+ models only. The voice control for VS is limited to turning on and off only.





SMART TECHNOLOGY.

With Solus, the combination of functionality through applied smart technology, it creates the ultimate home heating experience. Your appliance will synchronise with your smart device, such as phone or tablet, putting you in complete control. The latest sensor technology helps to create our most efficient appliance ever, ensuring that the room is heated to the correct temperature at the correct time with optimum energy usage.

We are committed to a sustainable future, ensuring that our appliances make the most efficient use of energy. All Solus appliances benefit from temperature detection and regulation technology; if there is a sudden drop in room temperature, perhaps caused by an open window or door, the appliance will temporarily deactivate any heating functions to avoid energy wastage and will reactivate when the window or door is closed.



OPTIONAL AMBIENT LIGHTING.

Extend the atmosphere beyond the fire and into the room using a Solus ambient lighting kit, allowing you to create a further interactive dimension to the environment. This additional lighting features 15 colour modes and can be controlled by the appliance remote control or via your smart device. The kit features a 3 metre length of RGB LED strip light and up to two kits can be simultaneously connected to a Solus appliance, making it the perfect addition to fire suites and media walls.



6 YEAR COMPREHENSIVE WARRANTY.

The Solus Collection: A Legacy of Excellence

For over 70 years, the Solus Collection has exemplified unmatched excellence in the fireplace industry. By seamlessly blending traditional craftsmanship with modern design, we have created uniquely stylish and functional products of the highest quality. Each Solus appliance reflects our unwavering commitment to quality excellence, meticulous attention to detail, and superior craftsmanship, ensuring you can choose Solus with confidence.

Our Warranty: A Promise of Quality

Every Solus appliance comes standard with a comprehensive 6-year warranty (parts & labour), provided it is purchased through an authorised dealer. This warranty underscores our dedication to delivering not just exceptional products, but also peace of mind. For appliances purchased outside our authorised dealer network, a statutory 1-year non-extendable warranty applies.

For full details and terms and conditions, please visit visionfires.co.uk





iX15 CORNER WITH BRICK EFFECT PANEL

SOLUS iX SERIES

Featuring **truburn** Flame Technology

Taking electric fires to a whole new level, the iX series features truburn flame technology, bringing electric fires to life like never before. Designed in-house using innovative techniques to create authentic moving flames, ultra realistic glowing logs and authentic sound effects to produce a convincing illusion a burning fire. The level of realism is truly unparalleled.

An optional brick effect panel upgrade is now available across all iX models, further enhancing the depth and authenticity of the fire's appliance.

The appliances feature a uniquely designed log arrangement, produced to specifically work in conjunction with an intricately created flame pattern that maps the contour of the logs. Each appliance comes with the option to install in a Front, Corner or Panoramic aspect.

- REAL GLOW LOGS
- ECO MODE
- 1.8kW HEAT
- COOL BLOW
- AUDIO FX



SEEING IS BELIEVING.
Scan the QR code for a video experience that will change the way you think about electric fires.

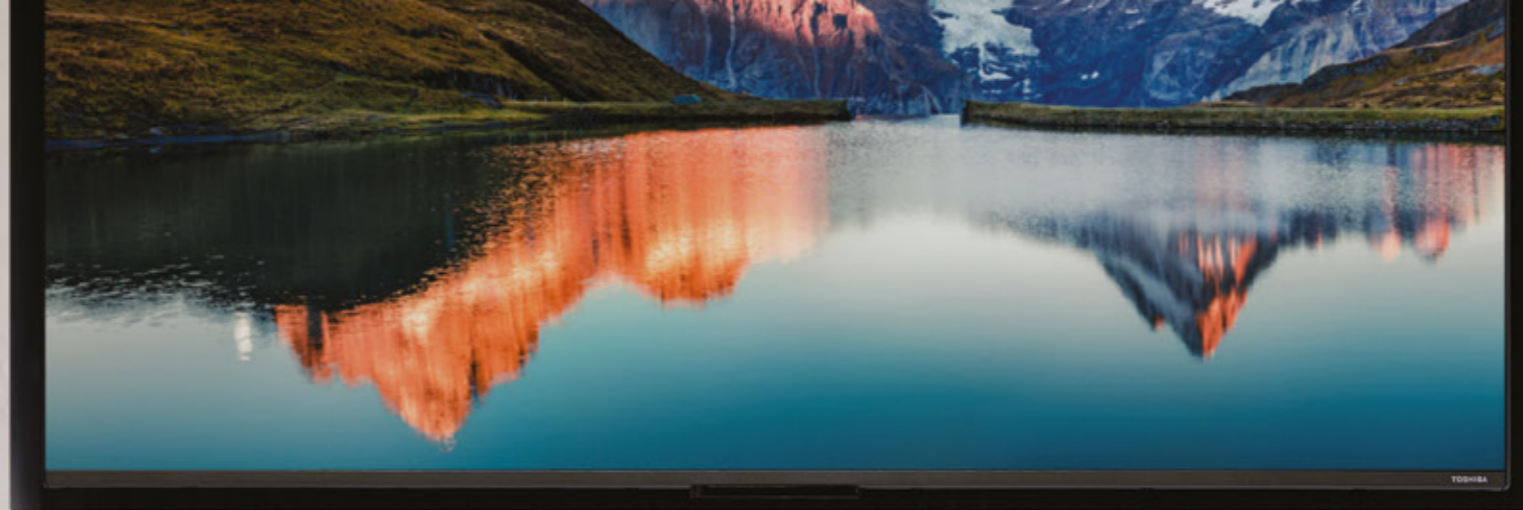

iX SERIES

Technical Specification

- New ultra-realistic flame effect with options for flame colour, flame type & flame height
- New feature to add smoke and sparks effect
- Flame effect can be operated with or without heat function
- Dynamic fuel bed featuring our most realistic logs yet, with internal dynamic illumination to mimic charring/glow
- Independent control of illumination for fuel bed, logs and downlight with colour change and brightness settings
- Realistic sounds with advanced speaker
- Easy to use remote control handset
- Easy to use App, controlled via your smart device
- 9 fuel bed colour options
- 'Favourite' mode to save your preferred flame/fuel bed settings
- 2 heat settings - 0.9kW & 1.8kW
- Cool blow function
- Thermostatic control
- Hourly timer mode
- 7-day programmable timer with adaptive smart heating
- Open window detection mode for optimised energy efficiency
- Solus Ambient Light Kit compatible (available as an optional additional purchase)
- Full Voice Control Integration seamlessly compatible with Alexa and Google



SOLUS iX10

Featuring **truburn** Flame Technology

Introducing the Solus iX10, our cutting-edge electric fire, celebrated for its incredibly realistic flame effect. This innovative appliance creates a convincing visual experience, delivering an enchanting ambiance with its lifelike flames.

With its considered design and advanced features, the Solus iX10 not only enhances the aesthetic of your space but also delivers efficient heating with just a touch of a button. The Solus iX10 can be installed in a front, corner, or panoramic configuration, allowing you to choose the perfect setup for your interior. Discover the allure and warmth of the Solus iX10, making it an exceptional choice for sophisticated interiors.



iX10 FRONT

For those seeking a bolder aesthetic, the iX10 features the eye-catching Manhattan trim as an optional extra. Detailed from a reassuringly heavy gauge, extruded aluminium, this four-sided fascia creates a sleek, yet intentional frame to showcase the mesmerising focal point within. The Manhattan trim is easy to install and provides the perfect finishing touch to any installation.



iX10 CORNER



iX10 PANORAMIC WITH BRICK EFFECT PANEL



SOLUS iX13

Featuring **truburn** Flame Technology

Presenting the Solus iX13, our advanced electric fire known for its astonishingly realistic flame effect. This state-of-the-art appliance offers an enchanting visual experience, creating a captivating ambiance with its lifelike flames.

The Solus iX13 boasts a sleek design and cutting-edge features, enhancing the aesthetic of your space while providing efficient heating at the touch of a button. The Solus iX13 can be installed in a front, corner, or panoramic configuration, allowing you to choose the perfect setup for your interior. Discover the beauty and warmth of the Solus iX13 and see why it's the perfect choice for elegant and sophisticated interiors.



iX13 PANORAMIC



iX13 FRONT



iX13 CORNER



SOLUS iX15

Featuring **truburn** Flame Technology

The Solus iX15 is our premium electric fire, renowned for its ultra-realistic flame effect. This state-of-the-art electric fire offers an exceptional visual experience, creating a captivating ambiance with its lifelike flames.

With its sleek design and advanced features, not only does the Solus iX15 enhance the look of your space but it also provides efficient heating at the touch of a button. Discover the beauty and warmth of the Solus iX15 and see why it's a standout choice for refined interiors.



For those seeking a bolder aesthetic, the iX15 features the eye-catching Manhattan trim as an optional extra. Detailed from a reassuringly heavy gauge, extruded aluminium, this four-sided fascia creates a sleek, yet intentional frame to showcase the mesmerising focal point within. The Manhattan trim is easy to install and provides the perfect finishing touch to any installation.



iX15 MEDIA SUITE.

Featuring **truburn** Flame Technology

The pinnacle of luxury in premium electric fires, celebrated for its ultra-realistic flame effect. Now featuring the Cupria Stone and White media suite, it combines a warm, grey/copper-coloured base with a striking, opaque white lacquered finish. This refined suite elevates any home with sophistication and natural charm.

Experience the state-of-the-art visual delight of the iX15 as its lifelike flames create a captivating ambience. The classic lines and sleek design of the iX15 Suite not only enhance your living space's elegance but also provide efficient heating at the touch of a button.

Discover the allure and comfort of the Solus iX15, a standout choice for those with a taste for refined interiors. Unveil an exceptional visual experience and enchant your home with its unique charm.





SOLUS iX18

Featuring **truburn** Flame Technology

Introducing the Solus iX18, the largest and most impressive fire in the iX Series. This state-of-the-art electric fire is renowned for its astonishingly realistic flame effect, delivering a mesmerising visual experience with lifelike flames that create a warm, inviting ambiance.

With its considered design and advanced technology, the Solus iX18 will enhance any space it occupies and provide efficient heating at the touch of a button. You can install each Solus iX18 appliance in a front, corner, or panoramic configuration, giving you the flexibility to perfectly match your interior setup. Experience the unmatched beauty and warmth of the Solus iX18, the ultimate choice for those seeking elegance and sophistication in their homes.





SOLUS VS & VS+ SERIES.

Whether you are planning on creating the ultimate social hub or simply increasing the wow-factor of your living space, make every detail matter with a Solus appliance from Vision Fires. Our approach is to create beautiful, inspiring electric fires that challenge expectations and redefine what a modern electric fireplace can be.

Now, the Solus VS range evolves with the introduction of the VS+ Series, a new generation of Solus excellence designed to build upon the iconic VS foundation. Retaining the same sleek exterior styling and familiar proportions, the VS+ models are carefully refined to deliver a richer, more immersive and more intuitive experience.

With a Solus fire, you remain in control of every element of your appliance, from the speed, colour, and brightness of the realistic flames to the atmospheric crackling log audio and the ambient lighting that enhances the surrounding living space.

Our exclusive TriLight technology sits at the heart of both the VS and new VS+ models, delivering multi-angled, fully customisable dynamic LED lighting. A vast range of colour and tonal combinations can be created across the flames and fuel bed, working independently or in harmony to create a truly personalised atmosphere at the touch of a button.

To demonstrate the possibilities, all Solus VS and VS+ fires include six pre-programmed lighting themes, carefully designed to showcase the depth, realism, and versatility of the range.



THE VS+ SERIES.

The Solus Collection has long been recognised for redefining electric fire design. Now, the VS+ Series takes that legacy to an exciting new level.

Carefully engineered and exquisitely refined, the VS100+, VS130+, VS150+, VS180+ and VS220+ represent the next evolution of the iconic VS range delivering enhanced realism, smarter control, and a deeper sense of atmosphere.

Retaining the same sleek exterior styling and familiar dimensions customers know and love, each VS+ model has been meticulously enhanced beneath the surface. Every refinement has been purposefully designed to offer a richer, more immersive, and more intuitive experience, elevating both the aesthetic impact of the fire and the ambience of the living space it inhabits.

REFINED PERFORMANCE. INTELLIGENT CONTROL.



VS+ SERIES KEY ENHANCEMENTS.

From upgraded flame technology to advanced control options, the VS+ Series introduces an exclusive suite of premium enhancements that transform the everyday fireplace into a truly considered centrepiece.

- **Ultra-Realistic Illuminated Log Set**
A beautifully enhanced log display with refined texture, richer tones, and full colour and brightness control, allowing you to tailor warmth and ambience to suit every moment.
- **Enhanced Flame Colour Palette**
A newly developed range of flame colours delivers greater depth, vibrancy, and realism, creating a captivating flame picture with remarkable authenticity.
- **Full Voice Control Integration**
Seamlessly compatible with Alexa and Google, enabling hands-free adjustment of flame effects, heat settings, and lighting through simple voice commands.
- **Extended Ambient Lighting Compatibility**
Designed to work harmoniously with wider ambient lighting options, allowing coordinated room illumination that synchronises effortlessly with the fire.
- **Premium Wall-Mounted Remote Holder**
Comes as standard across all VS+ models. This refined and practical addition that keeps your remote control elegantly displayed and conveniently within reach.

OPTIONAL EXTRA
Wired Wall Control Panel Compatibility
A high-end, permanently installed control option offering precise management and a truly integrated living environment.

A REFINED CLASSIC REIMAGINED

The VS+ Series combines the unmistakable Solus aesthetic with significant internal advancements, delivering a deeper flame experience, enhanced customisation, and smarter, more intuitive control.

The same contemporary Solus design now elevated with superior performance, greater realism, and next-level control.



SOLUS VS SERIES

Whether you are planning on creating the ultimate social hub or simply increasing the wow-factor of your living room, make every detail matter with a Solus appliance from Vision Fires. Our approach is to create beautiful, inspiring appliances that change the perception of a traditional electric fire.

With a Solus fire, you are in control of every aspect of your appliance, from the speed, colour and brightness of the entrancing flames to the enchanting crackling sounds of burning logs, or the complementing ambient lighting of your extended living space.

Our unique TriLight technology provides multi angled, fully customisable dynamic LED lighting to create thousands of unique colour and tonal combinations to the flames and fuel bed. Each can work in harmony with one another or can work independently to create a unique combination to create a truly unique atmosphere, all at the touch of a button.

To provide an insight into the possibilities, all Solus fires come with 6 programmed themes to highlight some of the fascinating lighting combinations that can be created. Please see the VS technical specification on page 39 for more information.



SEEING IS BELIEVING.

Scan the QR code for a video experience that will change the way you think about electric fires.



VS SERIES

Technical Specification

Create something truly breath-taking with a Solus appliance. Space enhancing, stylish and practical, our appliances are available in a range of shapes and sizes that can be fitted to your exact specification.

- Realistic flame effect that can be operated with or without heat function
- Dynamic fuel bed featuring realistic logs
- Easy to use remote control handset
- Easy to use App, controlled via your smart device.
- Variable flame speed
- 9 flame effect colour options
- 9 fuel bed colour options
- 'Favourite' mode to save your preferred flame/fuel bed settings
- 2 heat settings - 0.9kW & 1.8kW
- Cool blow function
- Thermostatic control
- Hourly timer mode
- 7-day programmable timer with adaptive smart heating
- Open window detection mode for optimised energy efficiency
- Option for ambient lighting kit

Solus fires come with 6 programmed themes:





FOR THE ULTIMATE IN PERFECTION, LOOK TO NATURE!

The Coppice Real Log Set provides a beautifully authentic enhancement for Solus VS Series appliances. Hand-crafted using carefully selected natural logs, it forms a realistic latticed fuel bed, complemented by forest-floor embers to create a truly natural flame presentation.

Each Coppice log set is individually produced in the UK using locally sourced materials. The logs are expertly bonded into a single, easy-to-install arrangement, delivering a refined and considered finishing touch to your fire.

The Coppice Real Log Set is available across the VS and VS+ range.

The VS model is supplied with the Coppice log set as standard, provided it is requested at the point of sale.

VS+ appliances are supplied with illuminated logs as standard. Customers may opt for the Coppice real log set as an additional upgrade, which replaces the illuminated log feature.

As the Coppice Real Log Set is crafted from natural materials, subtle variations may occur between each fuel bed. While the overall layout remains consistent, these natural differences enhance the individuality and authenticity of every installation.





VS75.

The VS75 is a versatile fire, perfectly at home in a contemporary setting or more traditional environments. The large glass viewing panel is perfectly suited for use with our modern furniture elements or with a complementing fireplace mantel, bringing a welcome sense of grand stature.

Coppice Real Log upgrade now available as standard on this appliance. See page 47 for details.





VS100 CORNER

VS100.

Add luxury to your living space with the VS100, the ultimate home investment. The VS100 is the smallest of our landscape electric fires at 1 metre in length. With an option of inset, panoramic or corner aspect you will be spoilt for choice when creating your perfect fireplace.

A range of versatile plinths and shelves are available to complement the VS100. They are flawlessly constructed from high quality materials. The classical crafted lines are a beautiful way to enhance any living space. The highly versatile plinths and shelves allow you to mix and match to suit your requirements. See page 43 for examples or please ask your approved stockist for details.

Coppice Real Log upgrade now available as standard on this appliance. See page 47 for details.



VS100 PANORAMIC WITH
WHITE TOP SHELF & BOTTOM
ANTHRACITE SHELF

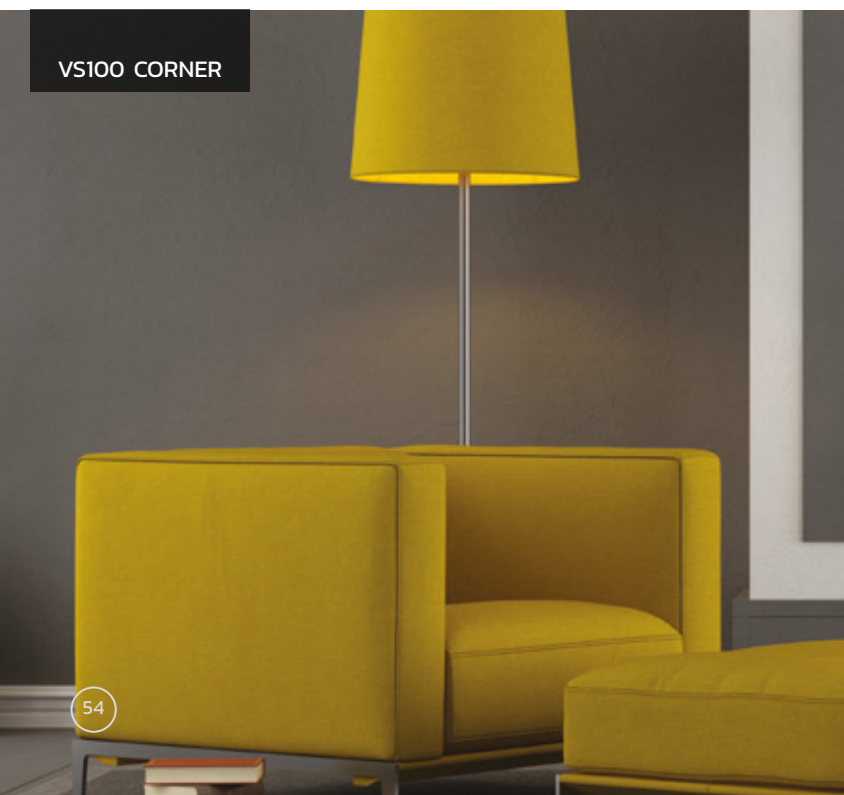

VS100 CORNER



VS100 PANORAMIC



VS100 PANORAMIC WITH
ANTHRACITE SHELF &
WHITE PLINTH

VS130.

At 1.3 metres in length, the VS130 is ideal for a range of interiors with its minimalist design themes. Add a sense of wonder to your home and bring it to life with the touch of a button.

Coppice Real Log upgrade now available as standard on this appliance. See page 47 for details.





VS130 PANORAMIC



VS130 FRONT



VS130 CORNER



VS150.

Whether you want to update or build a contemporary dream home, the VS150 will transform any room with a sense of luxury. This fire is 1.5 metres in length and can be installed in either inset, panoramic or corner aspect allowing you full creative control.

A range of versatile plinths and shelves are available to complement the VS150. They are flawlessly constructed from high quality materials. The classical crafted lines are a beautiful way to enhance any living space. The highly versatile plinths and shelves allow you to mix and match to suit your requirements.

Coppice Real Log upgrade now available as standard on this appliance. See page 47 for details.



VS180.

When you really want to create an impression, the VS180 really makes an impact. At 1.8 metres in length, this is sure to create an eye-catching centrepiece to any room.

Coppice Real Log upgrade now available as standard on this appliance. See page 47 for details.





VS180 PANORAMIC



VS180 FRONT



VS180 FRONT

VS220.

At 2.2 metres in length, the VS220 is the largest fire in the Solus Collection. This elegantly styled landscaped electric fire will fit seamlessly in a range of interiors. It's particularly suited to modern interior design styles. As impressive as it is, you are still in control of every aspect of the fire, from the speed, colour, and brightness of the captivating flames to the enchanting crackling sounds of burning logs.

Coppice Real Log upgrade now available as standard on this appliance. See page 47 for details.





OPTIONAL PLINTHS, SHELVES & SUITES

Indulge in the epitome of luxury with our exclusive range of versatile plinths, shelves and media suites, thoughtfully designed to complement the VS and VS+ ranges. Impeccably crafted from the finest materials, these exquisitely formed pieces embody timeless elegance and sophistication, enhancing the ambience of any living space.

Designed to work across the VS and VS+ models, the plinths, shelves and media suites offer a high level of design flexibility, allowing you to combine elements to create a truly bespoke installation.



SUITES, SHELVES & PLINTHS

NIRA SUITE.

The epitome of luxury, this suite is designed exclusively for the VS100 and the VS100+ electric fire. The striking light grey Chicago concrete effect sections, a staple in high-end interior design, seamlessly blends with the contemporary charm of the white top and bottom sections.

Crafted from high-quality materials, the Nira Suite showcases authentic concrete effect textures that amplify the aesthetic appeal of any home. Its classically crafted lines bring a refined elegance to your living environment, transforming your space into a luxurious haven.

Experience the exquisite beauty of the VS100 or the VS100+ Nira Suite, where luxury meets functionality. For those with a discerning eye, the Nira Suite paired with the VS100 electric fire is an unparalleled choice for refined interiors.





SUITES, SHELVES & PLINTHS

ZENITH SUITE IN CALACATTA.

The Zenith suite is expertly designed to complement both the VS100 and VS100+.

Crafted from Calacatta Honed Sintered Stone, this wonderfully appealing material utilises cutting edge technology to create an irresistible alternative to marble or quartz. The process of sintering takes natural mineral particles and forms them under incredible heat and pressure to produce a strong and durable material that is resistant to scratching, can withstand high temperatures, does not deteriorate, or discolour from UV rays, and is very easy to clean. Calacatta Honed Sintered Stone is an authentically accurate recreation of Calacatta marble with simple grey veining, adding depth to the smooth white finish that just begs to be touched.

SUITES, SHELVES & PLINTHS

ZENITH SUITE IN NERO.

The Zenith suite is expertly designed to complement both the VS100 and VS100+ models. Crafted from Nero Honed Sintered Stone, the striking aesthetic of this distinctive material is marked by uniqueness. The Nero offers a fully inverted appearance with an abundance of white veining against a deep black marble.

Demonstrating decades of manufacturing excellence, careful consideration has been taken to ensure alignment of the inimitable veining patterns across each component, creating a sense of continuity that conveys affluence and luxury.

Coppice Real Log upgrade available on this appliance see page 47 for details.





SUITES, SHELVES & PLINTHS

MALMO BENCH.

Introducing the Malmo, a masterclass in classic design and retro charm. The Malmo combines timeless design elements to create a captivating bench that stands out in any space. Its warm and rich walnut veneer is skilfully complemented by the delicate yet strong hairpin legs, showcasing a harmonious blend of form and function. This piece embodies elegance and sophistication, making it a perfect addition to both modern and traditional interiors. The Malmo is not just a piece of furniture; it's a statement of style and a testament to exceptional craftsmanship. Elevate your living space with the Malmo and experience the perfect fusion of aesthetics and practicality.

Paired with the VS150 or VS150+, this ensemble offers both visual and practical enhancements to your home. The Malmo fireplace complements the bench with its sleek, contemporary design, customizable flame settings, and energy-efficient performance. Together, they create a cohesive and stylish ambiance, transforming any living space into a haven of luxury and comfort.



CANOVA PLINTH
IN CALACATTA

SUITES, SHELVES & PLINTHS

CANOVA PLINTH IN CALACATTA.

The Canova Plinth, designed specifically for the Solus VS150 and VS150+ electric fire. This sleek and stylish plinth enhances the visual appeal of your electric fire, providing a sophisticated and modern base that complements the elegant design of the Solus VS150 or VS150+.

Crafted with precision and attention to detail, the Canova Plinth offers a seamless integration that elevates your home's décor while adding a touch of luxury.

Elevate your fireplace experience with the new Canova Plinth and transform your space with contemporary elegance.



CANOVA PLINTH IN NERO.

The Canova Plinth in Nero is designed specifically for the Solus VS150 and VS150+ electric fire. This sleek and stylish plinth enhances the visual appeal of your electric fire, providing a sophisticated and modern base that complements the elegant design of the Solus VS150 and VS150+.

Crafted from Nero Honed Sintered Stone, the striking aesthetic of this distinctive material is marked by uniqueness. The Canova Plinth offers a seamless integration that elevates your home's décor while adding a touch of luxury. The Nero offers a fully inverted appearance with an abundance of white veining against a deep black marble. Demonstrating decades of manufacturing excellence, careful consideration has been taken to ensure alignment of the inimitable veining patterns across each component. Elevate your fireplace experience with the new Canova Plinth and transform your space with contemporary elegance.





SUITES, SHELVES & PLINTHS

MEDIA SUITE.

Indulge in the epitome of modern elegance with a Media Suite, available in Cupria Stone, White, or a striking combination of both, designed to complement both the VS150 and VS150+.

- Cupria Stone: This option boasts a warm, natural charm with its copper-coloured base, enhancing the rich black stone effect. Perfectly complemented by bronze, copper, or red wood tones, the Cupria Stone brings a sophisticated touch to any home.
- White: The neutrality of the white finish creates a striking contrast. It provides the effect of an opaque white lacquer, resulting in a natural finish.

The classic lines of the Media Suite offer timeless beauty, designed specifically to suit the VS150 and VS150+ appliances. With a sleek design, this media suite provides an unrestricted view of the mesmerising fire from every angle in the room, all at the touch of a button.

Elevate your interior with the unparalleled refinement of a Media Suite and experience the captivating ambiance it brings to your living space.

MEDIA SUITE
IN WHITE



MEDIA SUITE IN CUPRIA
STONE EFFECT



MEDIA SUITE IN CUPRIA STONE EFFECT
WITH WHITE BOTTOM PLINTH



MEDIA SUITE IN WHITE WITH
CUPRIA STONE EFFECT BOTTOM PLINTH



SHELVES & PLINTH OPTIONS FOR VS & VS+ FIRES

The sleek, contemporary Anthracite shelf and the clean, elegant White top shelf each bring their own distinctive style to modern interiors, while the White floor plinth provides a fresh, refined foundation to complete the look. Designed to integrate seamlessly with compatible VS and VS+ appliances, each piece enhances the overall aesthetic, beautifully framing the fire or creating a stylish base.

These elements can be used individually to achieve a tailored finish, or combined* for a cohesive, design-led statement. When paired with a three-sided fire, they create a striking focal point, delivering an uninterrupted view of the flames from every angle, effortlessly controlled at the touch of a button.

*Please note: not all elements are compatible with every model size. See the compatibility list below for details.

White Floor Plinth to suit VS75, VS100/VS100+, VS150/VS150+

White Top Shelf to suit VS100/VS100+, VS150/VS150+

Anthracite Bottom Shelf - to suit VS75, VS100/VS100+, VS130/VS130+ VS150/VS150+

VS100 ANTHRACITE BOTTOM SHELF & WHITE TOP SHELF



VS75 ANTHRACITE BOTTOM SHELF & WHITE FLOOR PLINTH



VS150 & WHITE TOP SHELF, WHITE FLOOR PLINTH & ANTHRACITE BOTTOM SHELF



iX APPLIANCE DIMENSIONS.

All dimensions are in millimetres.

iX10 Panoramic/Corner

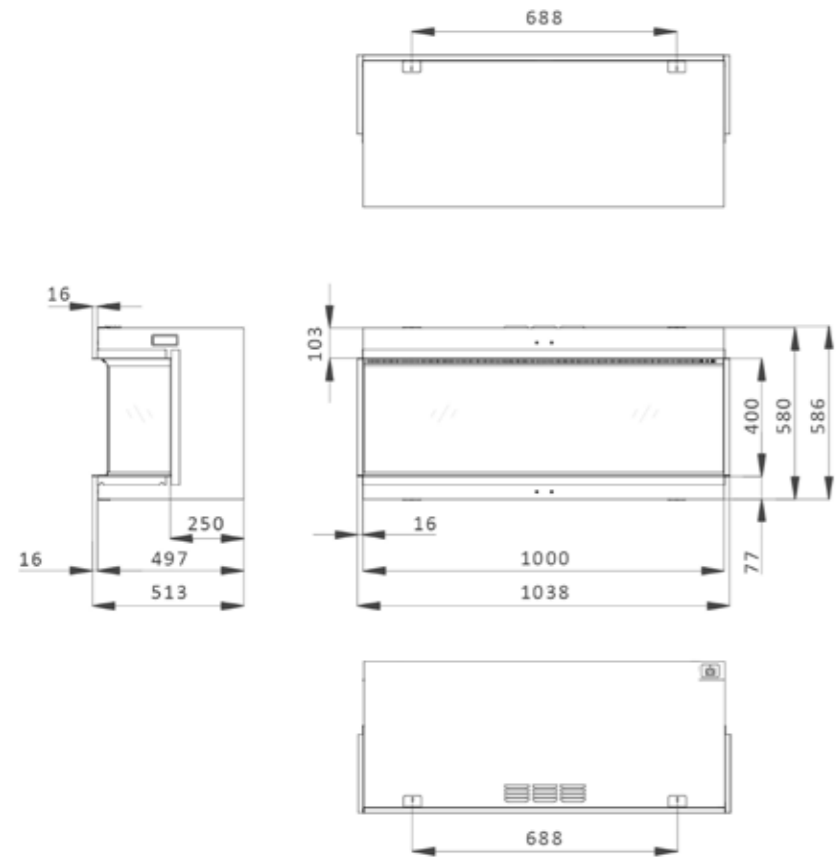

iX10 Front

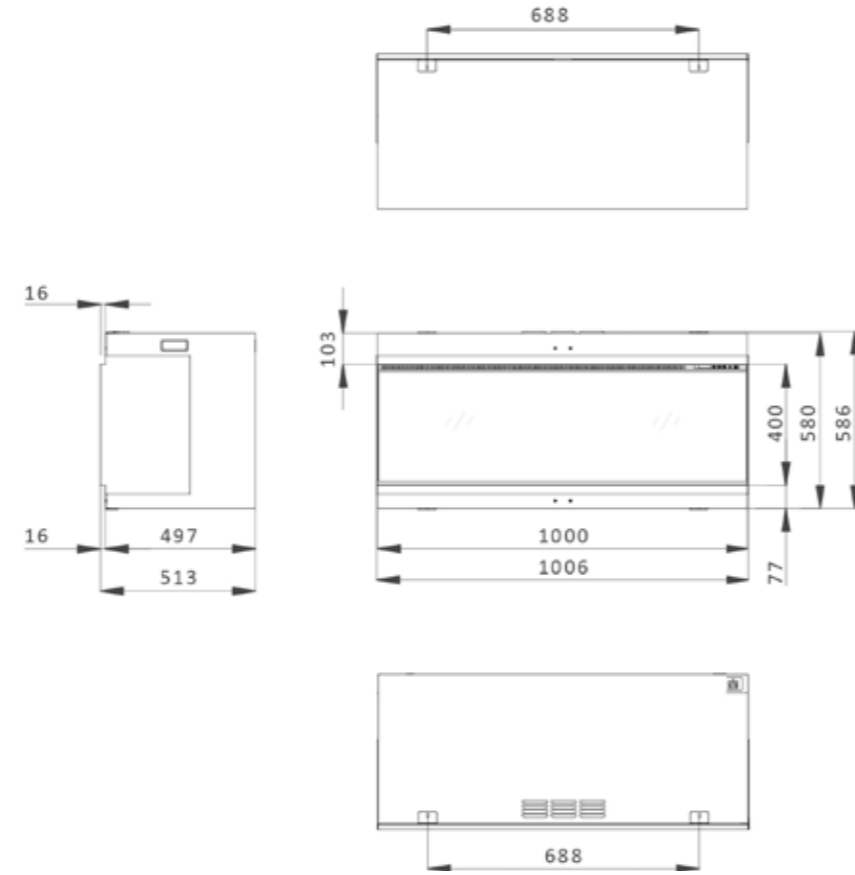

iX13 Panoramic/Corner

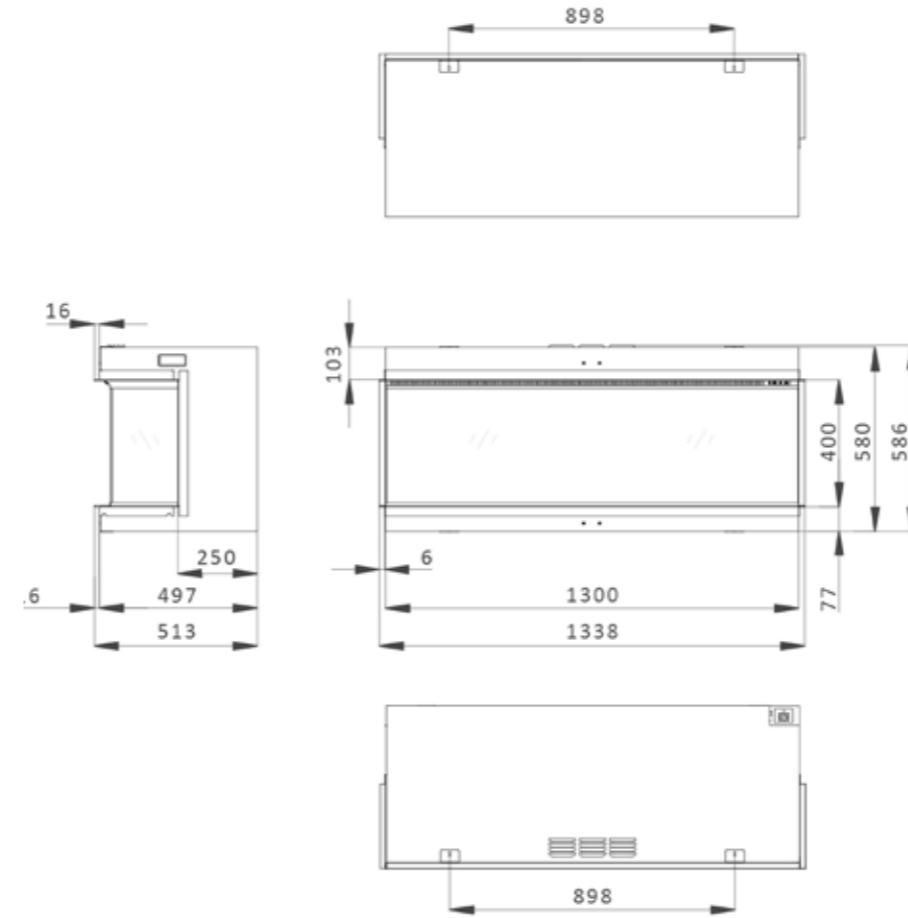

iX13 Front

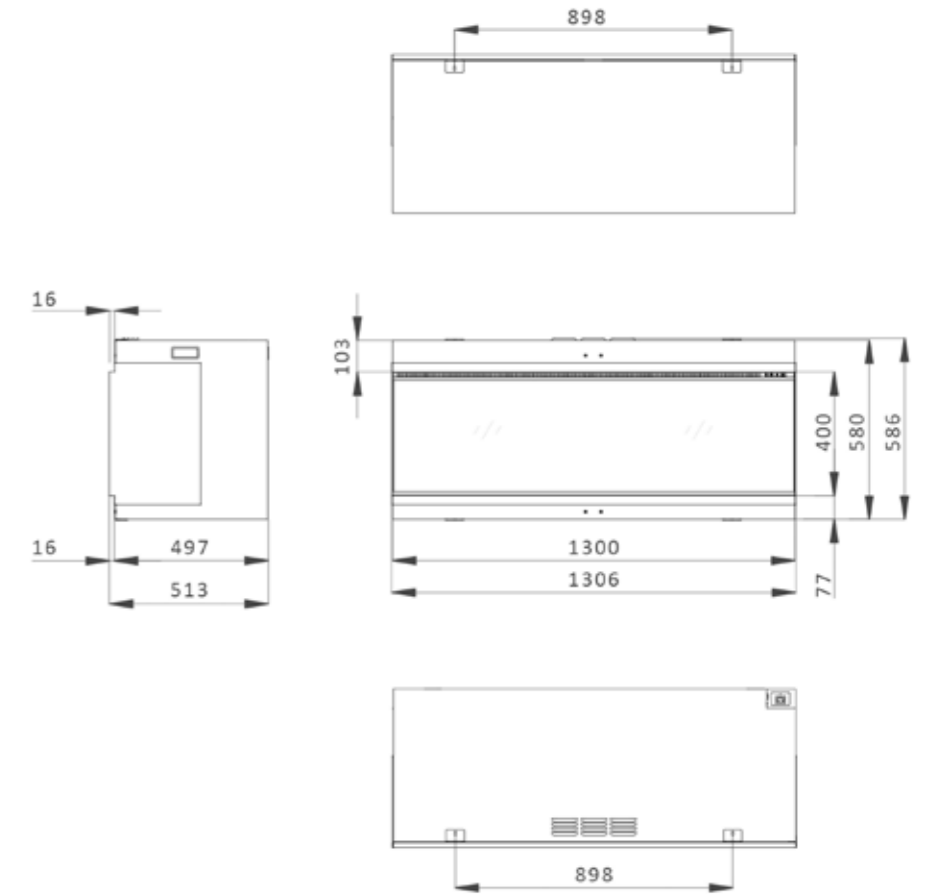

iX APPLIANCE DIMENSIONS.

All dimensions are in millimetres.

iX15 Panoramic/Corner

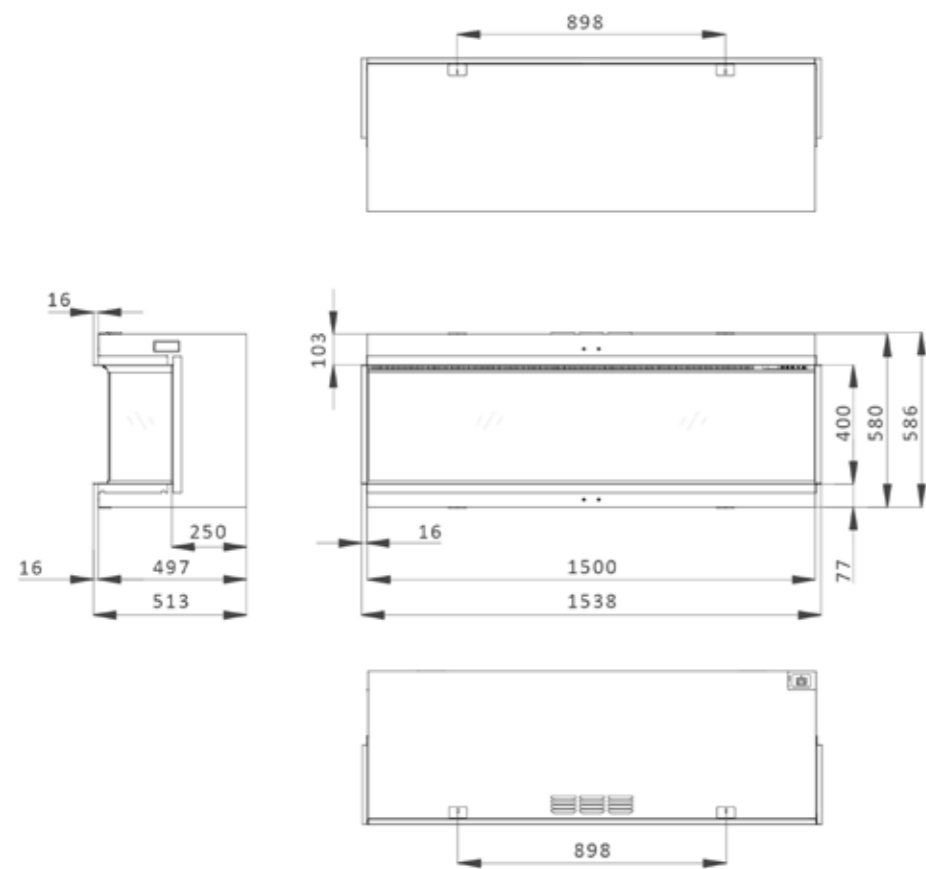

iX15 Front

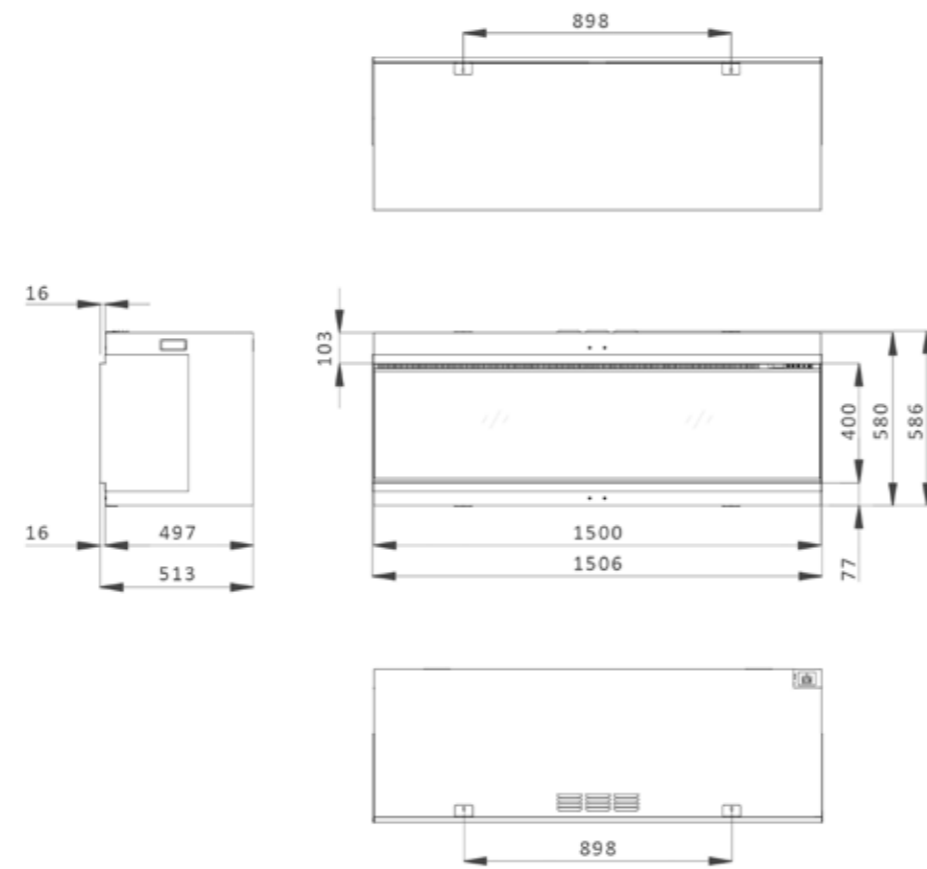

iX18 Panoramic/Corner

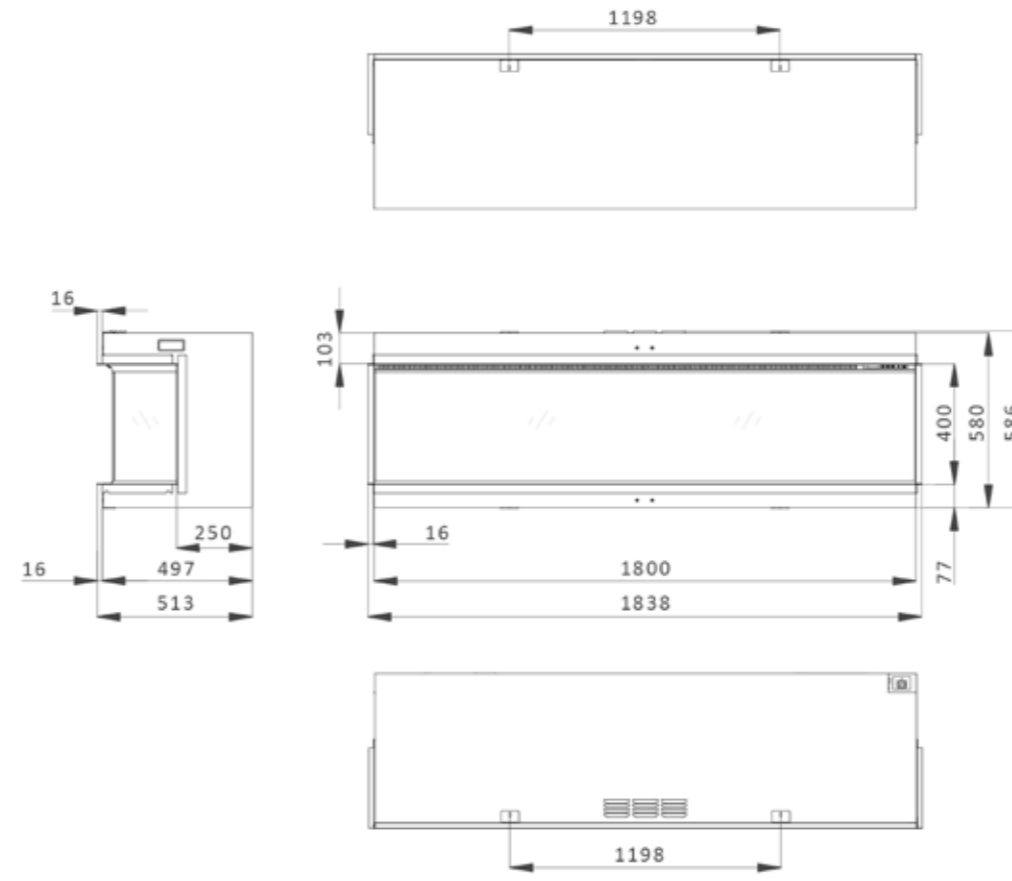

iX18 Front

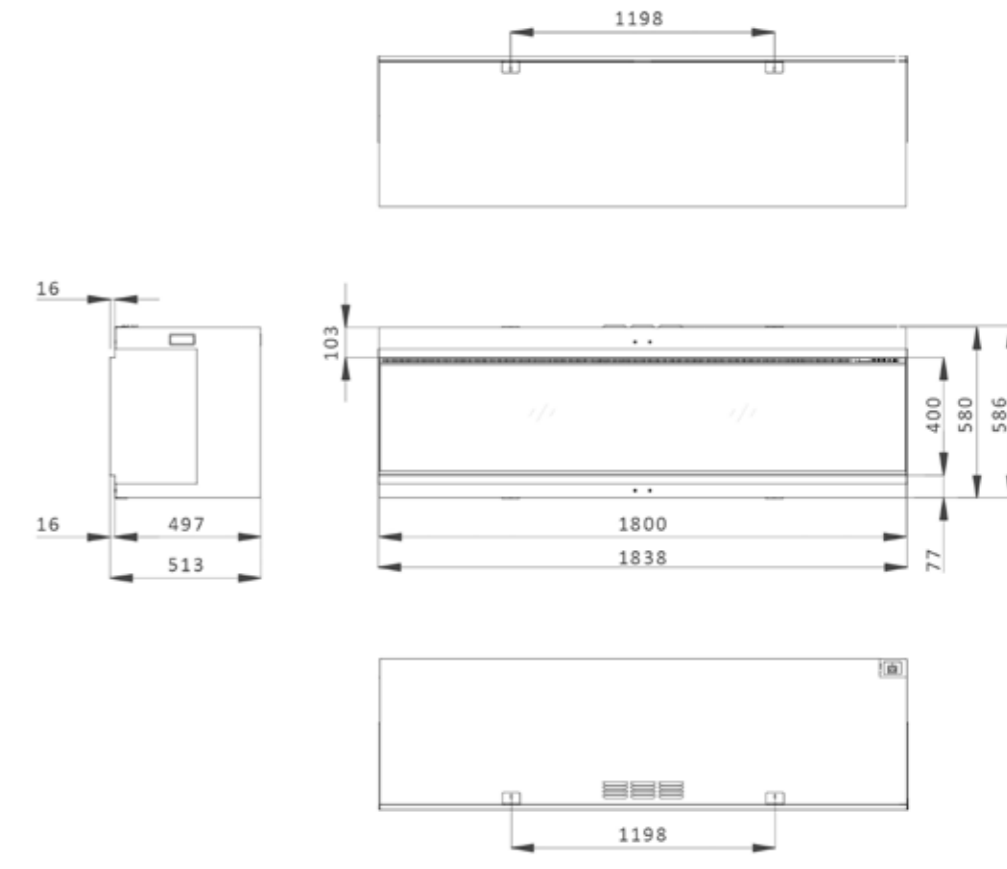

iX APPLIANCE DIMENSIONS.

All dimensions are in millimetres.

iX15 Media Suite

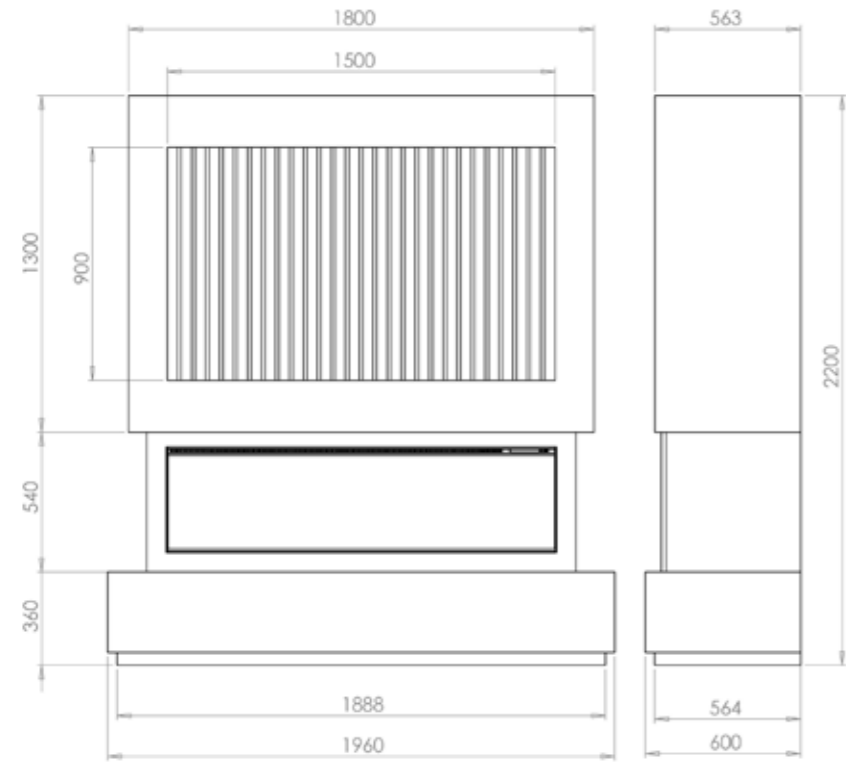

iX10 Trim (50mm)



iX15 Trim (50mm)

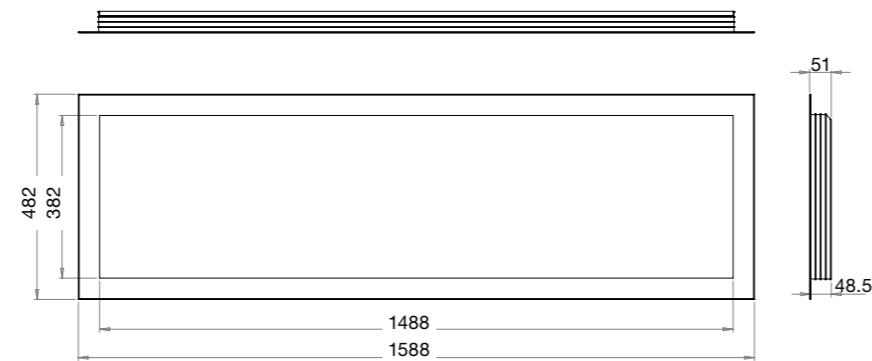

VS AND VS+ APPLIANCE DIMENSIONS.

All dimensions are in millimetres.

VS75

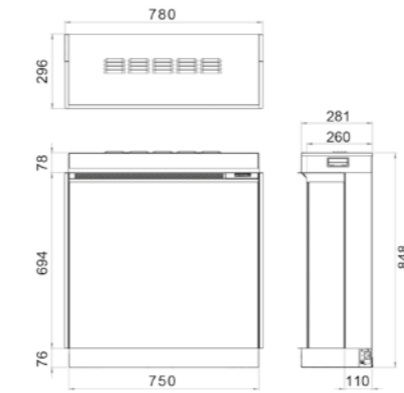

VS100 / VS100+

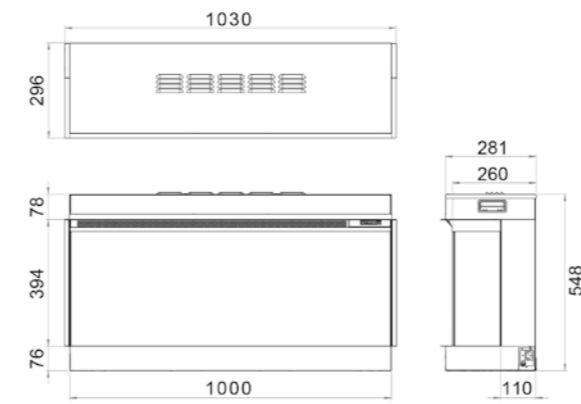

VS130 / VS130+

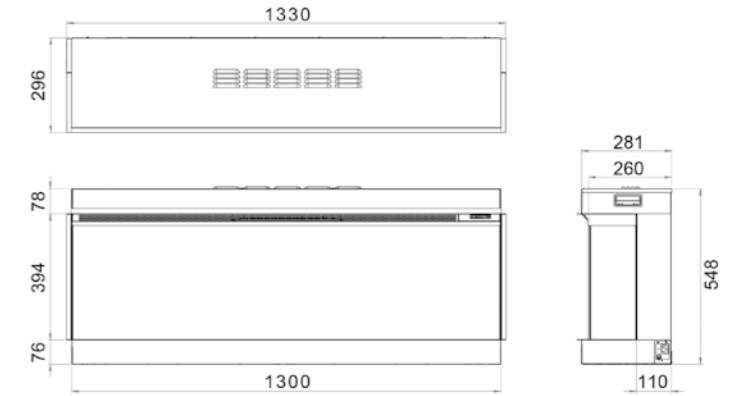

VS150 / VS150+

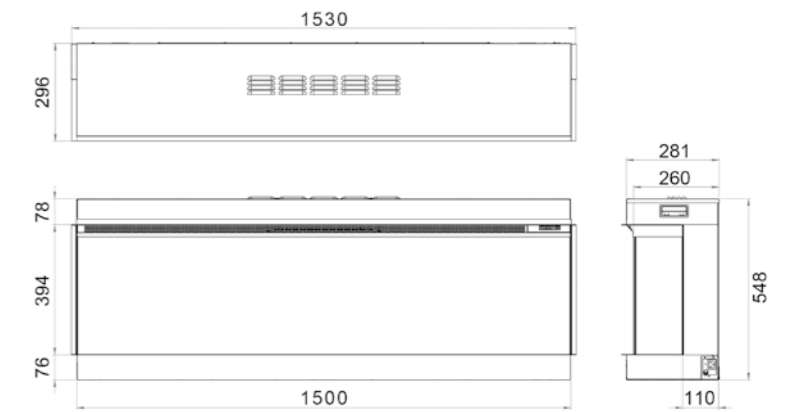

VS & VS+ APPLIANCE DIMENSIONS.

All dimensions are in millimetres.

VS180 / VS180+

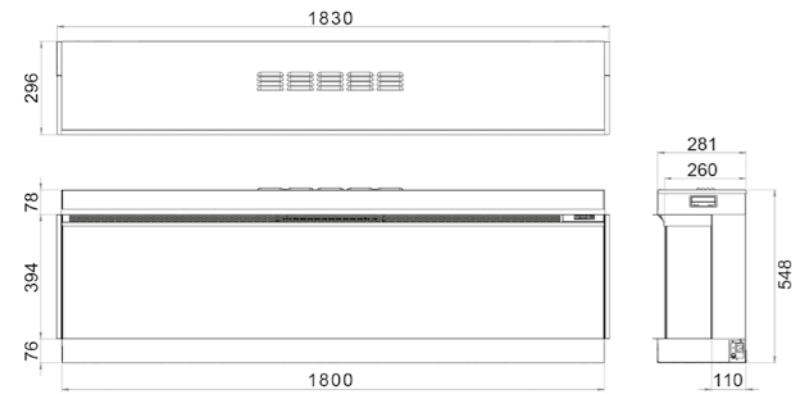

VS220 / VS220+



PLINTHS, SHELVES & SUITES DIMENSIONS

All dimensions are in millimetres.

Media Suite to suit VS150 / VS150+

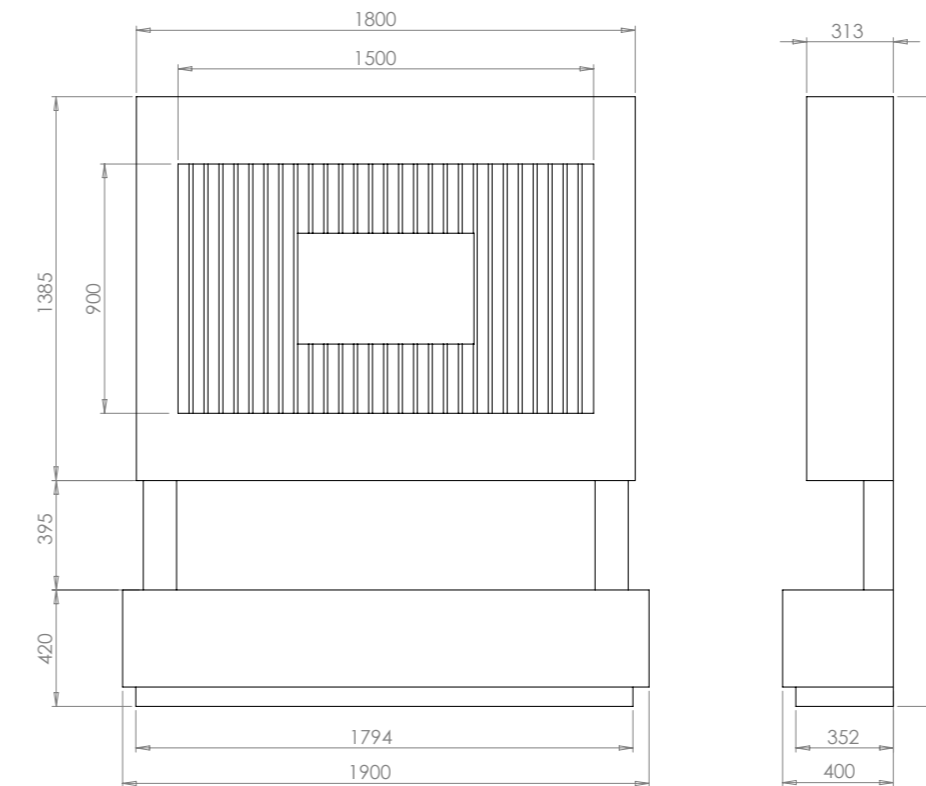

Nira Suite to suit VS100 / VS100+

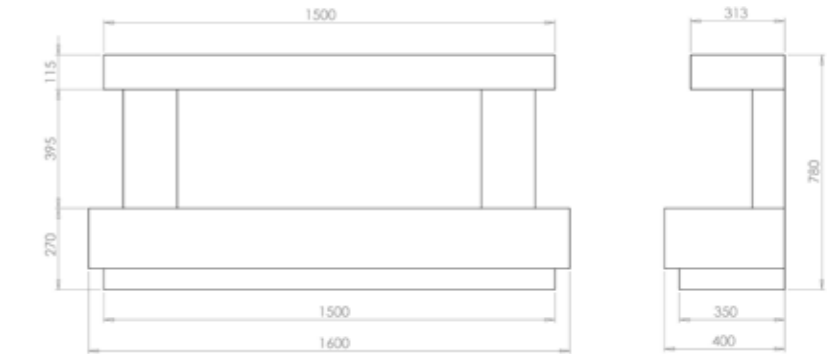

Zenith Suite to suit VS100 / VS100+

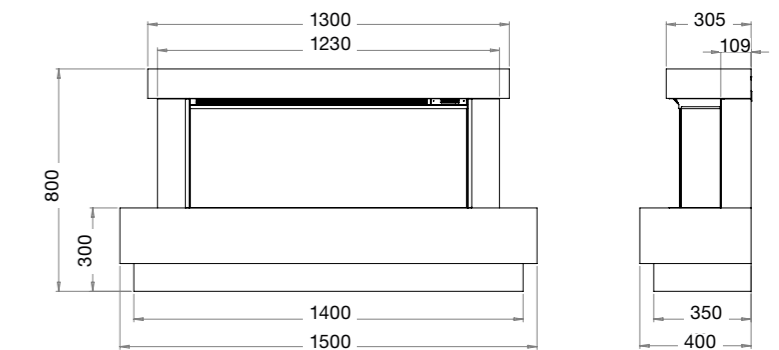

OPTIONAL PLINTHS, SHELVES & SUITES.

All dimensions are in millimetres.

VS75 Bottom Shelf

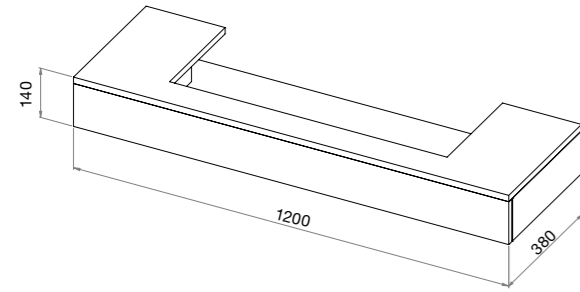

VS75 Floor Plinth

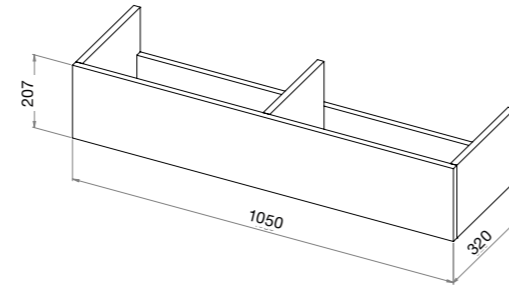

Top Shelf to suit VS100 / VS100+

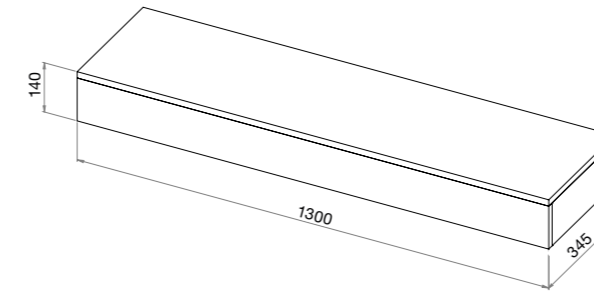

Bottom Shelf to suit VS130 / VS130+

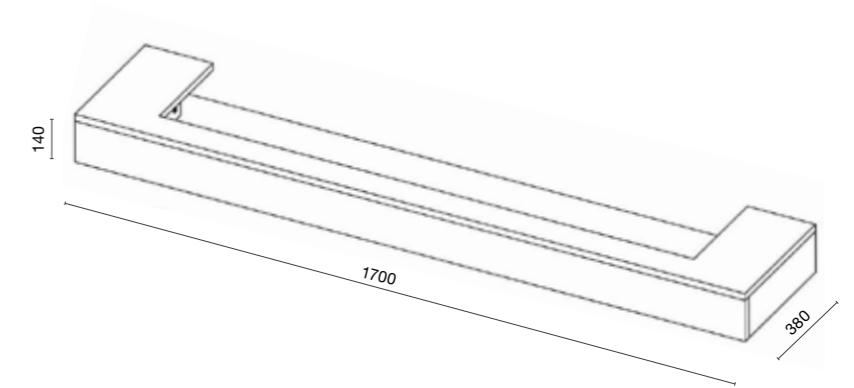

Bottom Shelf to suit VS100 / VS100+

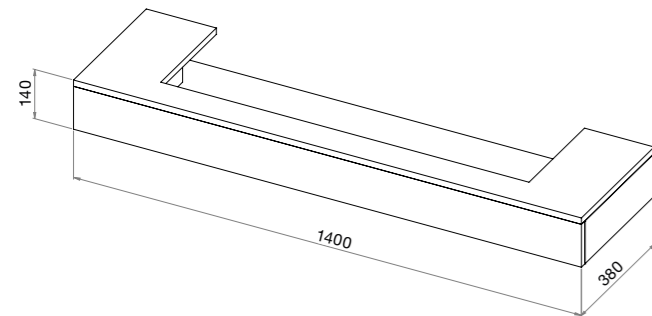

Floor Plinth to suit VS100 / VS100+

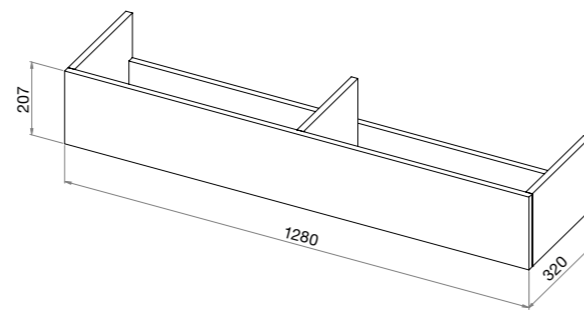

Bottom Shelf to suit VS150 / VS150+

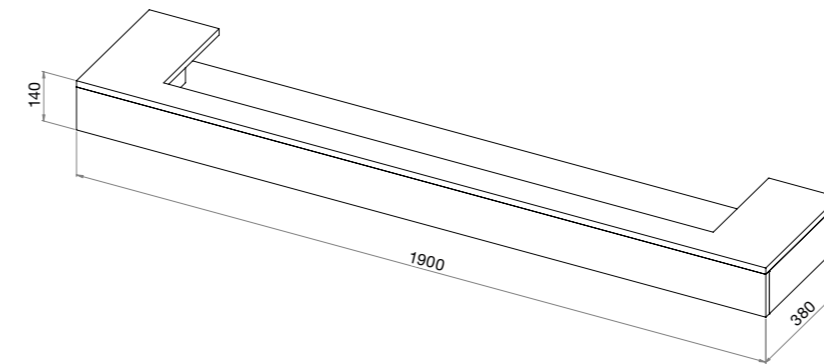

Floor Plinth to suit VS150 / VS150+

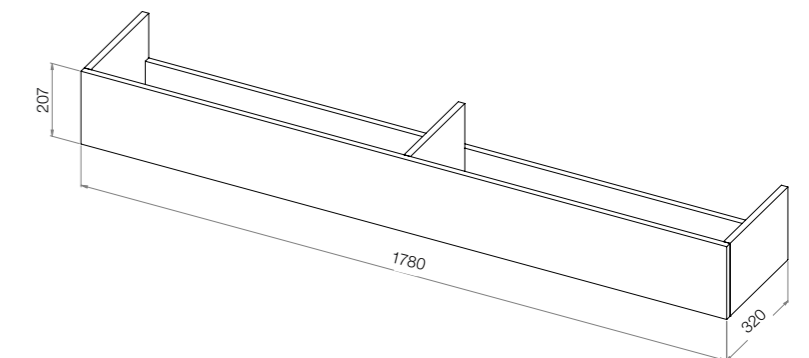

OPTIONAL PLINTHS, SHELVES & SUITES

All dimensions are in millimetres.

Top Shelf to suit VS150 / VS150+

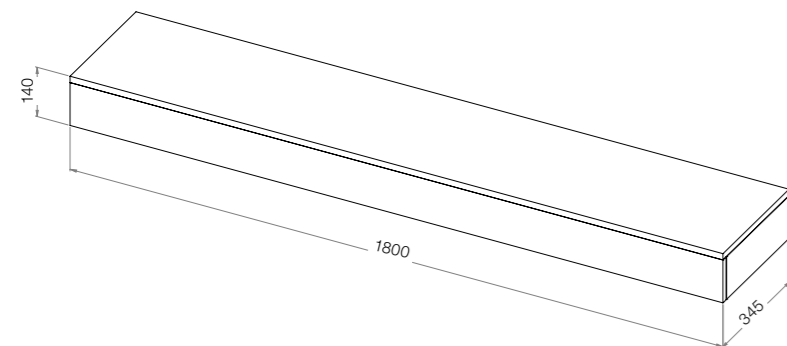

Canova Plinth to suit VS150 / VS150+

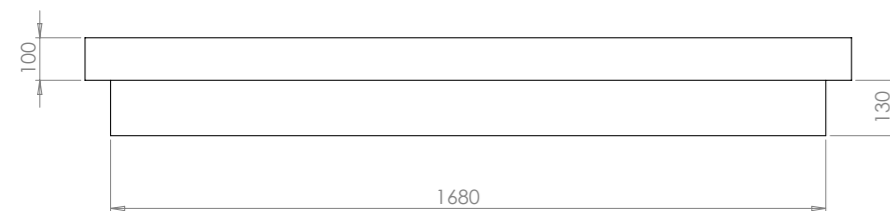
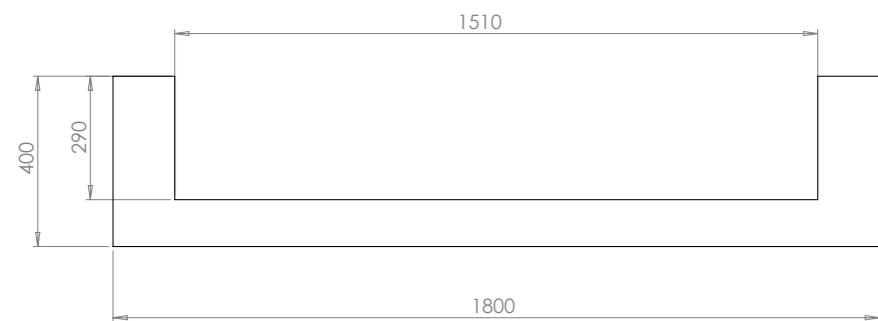

MORE THAN AWARD-WINNING ELECTRIC FIRES



ELECTRIC PERFECTION

THERE IS PREMIUM, & THEN THERE IS VISION.

Our fires don't just look incredible, they are the most realistic electric fires available. Powered by our groundbreaking Truburn Flame Technology, they deliver the most realistic, dynamic, and immersive flame experience on the market.



TRUBURN FLAME TECHNOLOGY

MORE NATURAL. MORE ATMOSPHERIC. MORE REAL.

Our exclusive flame engine creates depth, movement, and colour accuracy that brings every flame to life.



6-YEAR INDUSTRY LEADING WARRANTY

We are so confident in our engineering and build quality that our products carry a 6 year warranty, providing exceptional peace of mind and true long term reliability.



RECOGNISED FOR DESIGN, REALISM & INNOVATION

Solus fires set the benchmark for flame effect quality and premium craftsmanship.



UNRIVALLED TECHNICAL SUPPORT

RELIABLE, EFFICIENT AND DEDICATED TO EXCELLENCE.

Our in house support team is knowledgeable, friendly, and committed to helping customers throughout their entire journey. On the rare occasion something goes wrong, our field engineers typically attend within five working days, often sooner.

SOLUS

VISION FIRES

TECHNOLOGY CRAFTED FOR REALISM

Service built around you. Design that speaks for itself. Choose an electric fire dependable support, and long lasting performance, the details that truly elevate the customer experience.

6 YEAR COMPREHENSIVE WARRANTY

The Solus Collection is built on over 70 years of experience in the fireplace industry, using traditional skills alongside modern design methods to create unique, high quality stylish and functional products. Quality excellence is an integral aspect of all our appliances, our meticulous attention to detail, high standards and quality craftsmanship means you can be confident in choosing a Solus appliance. As standard Solus appliances come with a 6-year warranty (parts & labour) subject to terms and conditions* when purchased through an authorised dealer. Appliances purchased outside of our authorised dealer network will carry a statutory 1-year non-extendable warranty. Details and full terms and conditions can be found at visionfires.co.uk Please visit www.visionfires.co.uk/warranty to register your appliance. Find your nearest solus approved stockist at www.visionfires.co.uk/find-a-solus-retailer

*Please visit www.visionfires.co.uk/warranty for details.

BROCHURE PHOTOGRAPHY

All the images throughout this brochure are for illustrative purposes only. The colours shown in the brochure are as accurate as possible, however some natural materials may vary due to the nature of the products.

DISCLAIMER

The brochure was correct at the time of printing, we reserve the right to change or withdraw details, prices, or specifications without prior notice. Every effort has been made to ensure the accuracy of information in this brochure. All dimensions are given for your convenience and should only be used as a guide. Colour reproduction is as accurate as current printing methods allow. We cannot be held responsible for changes or matters outside our control.

SOLUS

ELECTRIC PERFECTION.

01204 868 550 | info@visionfires.co.uk | www.visionfires.co.uk