

VISION
trimline

INSTALLATION INSTRUCTIONS

FOR MODEL

TL60cf Conventional Flue



CONTENTS

1.0 APPLIANCE TECHNICAL SPECIFICATION	Page 4
1.1 TL60cf Dimensions	
1.2 TL60cf Parts	
1.3 Gas technical information	
2.0 INSTALLATION INFORMATION	Page 7
2.1 General information	
3.0 CHINMNEY AND FLUE PREPARATION	Page 8
3.1 Preparation	
3.2 Installation of flue liner	
3.3 Finished fireplace opening	
4.0 INSTALLING THE APPLIANCE	Page 9
4.1 Connecting the gas lines	
4.2 Preparation and installation	
4.3 Installing the gas control GV60	
4.4 I.O. switch	
4.5 Battery pack	
5.0 PLACEMENT OF THE CERAMIC LOG SET	Page 10
5.1 Natural Gas G20	
5.2 LPG G30-31	
5.3 Ceramic log placement	
6.0 TECHNICAL DETAILS GV60	Page 12
7.0 INSTRUCTIONS FOR MERTIK MAXITROL GV60 GAS CONTROL	Page 13
8.0 TROUBLESHOOTING FLOW CHART MERTIK GV60	Page 14
9.0 PROBLEMS AND POSSIBLE SOLUTIONS	Page 17
APPENDIX 1 DIMENSIONAL DRAWINGS	Page 18
APPENDIX 2 INSTALLATION EXAMPLES	Page 19

1.0 APPLIANCE TECHNICAL SPECIFICATION

1.1 TL60cf Dimensions

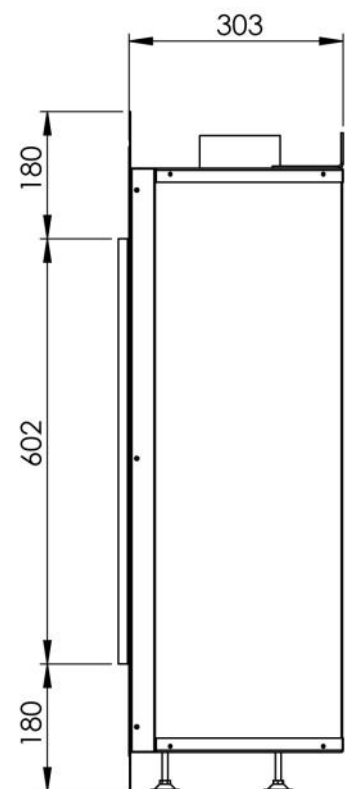
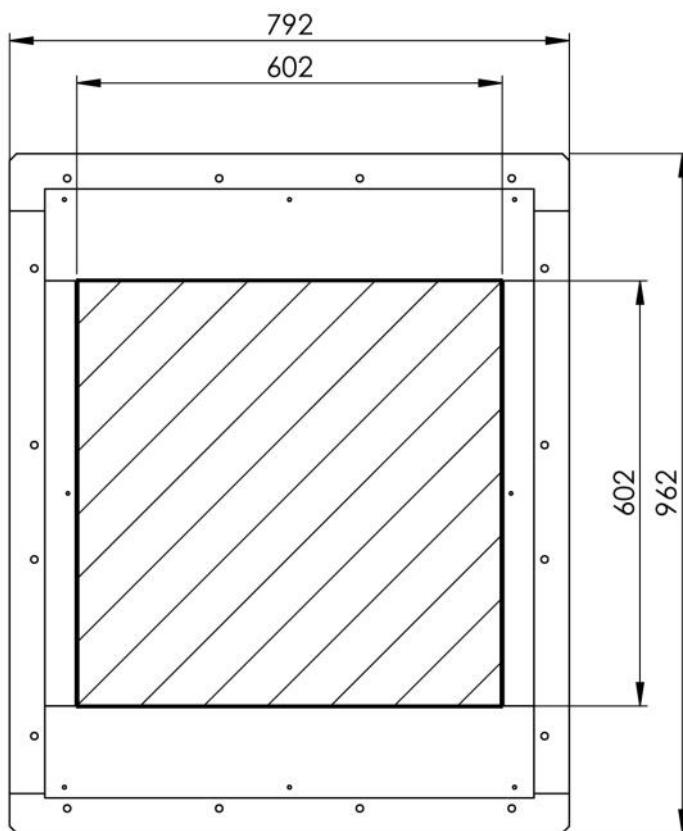
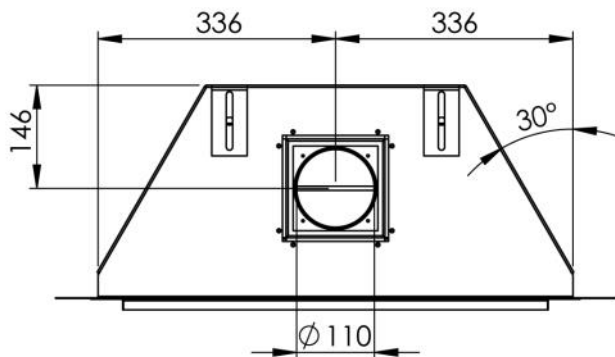

FEET AND BOTTOM FLANGE ARE REMOVABLE

1.0 APPLIANCE TECHNICAL SPECIFICATION

1.2 TL60cf Parts

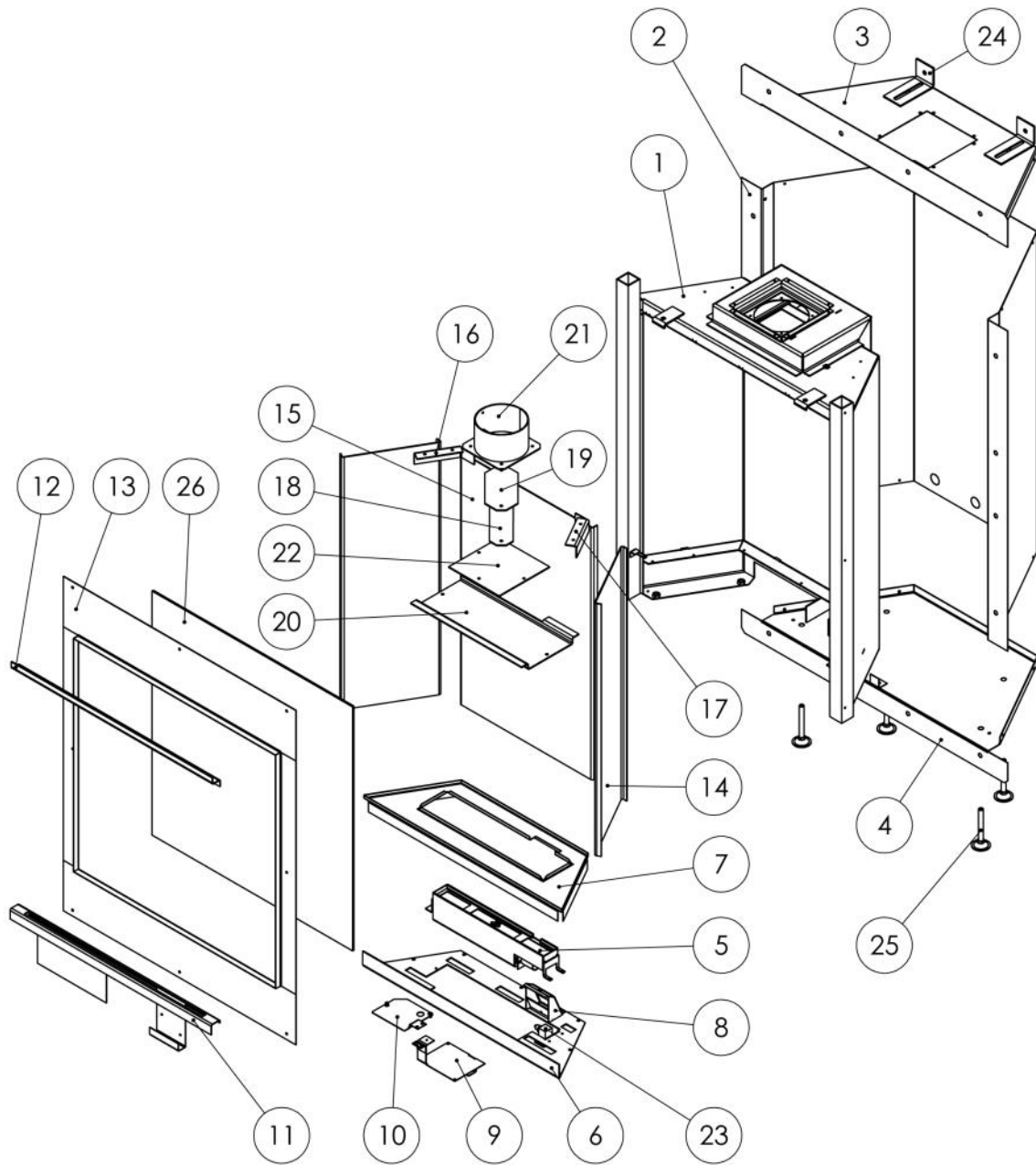

1	Combustion Chamber	6	Burner Tray	11	Bottom Glass Retainer	16	Panel Bracket Left	21	Flue Connector
2	Back/side Conv. Plate	7	Decorative Plate	12	Top Glass Retainer	17	Panel Bracket Right	22	Flue Connector Cover
3	Top Convection Plate	8	Oxypilot Mesh Protection	13	Glass Frame	18	50mm Restrictor Plate	23	Injector Bracket
4	Bottom Conv. Plate	9	Receiver Holder	14	Side Panel x 2 (Optional)	19	70mm Restrictor Plate	24	Wall Bracket
5	Burner	10	Gas Valve Holder	15	Back Panel (Optional)	20	Baffle Plate	25	Adjustment Feet x 4
								26	Glass Panel

1.0 APPLIANCE TECHNICAL SPECIFICATION

1.3 Gas Technical Data

GASTYPE		G20	G20/G25	G25	G20/G25	G30	G30	G30
CATEGORY		I2H/I2E	I2E+	I2L	I2ELL	I3+	I3B/P	I3B/P
PRIMARY AIR		2	2	1	2	7	7	7
PRE PRESSURE	MBAR	20	20/25	25	20	28-30	30	50
BURNERPRESSURE HIGH	MBAR	13,3	13,3	16,5	13,3	27,5	27,5	27,5
BURNERPRESSURE LOW	MBAR	3,8	3,8	4,8	3,8	10,2	10,2	10,2
INJECTOR SIZE	Ø MM	2,2	2,2	2,2	2,2	1,3	1,3	1,3
INJ. PILOTBURNER	CODE	NG 9043	NG 9043	NG9 043	NG 9043	LPG 9228	LPG 9228	LPG 9228
LOWSETTING SIZE	MM	0,9	0,9	0,9	0,9	1	1	1
INPUT Hi	KW	6,8	6,8	6,4	6,8/585	6,45	6,45	6,45
INPUT Hs	KW	7,56	7,56	7,11	7,56/6,5	7	7	7
CONSUMPTION	M ³ /h	0,720	0,720	0,788	0,720	0,2	0,2	0,2
NOM. INPUT	KW	5,1	5,1	4,7	5,1/4,4	4,8	4,8	4,8

Appliance has NoX Class 5

AT	I2H, I3B/P	BE	I2E+, I3+	DK	I2H, I3B/P	DE	I2E, I3B/P
FI	I2H, I3B/P	FR	I2E+, I3+	GR	I2H, I3B/P	GB	I2H, I3+
IS	I3B/P	IE	I2H, I3+	IT	I2H, I3+	LU	I2E, I3B/P

NOTE: The type plate is located on the inner side of the bottom glass retainer and can be accessed by lifting upwards and away from the glass.

2.0 INSTALLATION INFORMATION

NOTE: The installation should only be performed by an authorized gas engineer.

2.1 General information

- The gas fireplace must be installed, connected and inspected by a qualified fitter, according to national, regional, and local standards and regulations. Failure to install the appliance correctly could lead to prosecution. **Read these instructions fully before beginning any installation work.**
- The flue system and the terminals must meet the requirements outlined in the applicable standards and regulations.
- The chimney/fireplace that the appliance is installed with, whether existing or purpose built, must be made from non-combustible materials.
- The temperature of the walls and shelves near the side and back of the unit may not be more than 80°C higher than the temperature of the environment.
- The product needs to be serviced and inspected by the fitter for local gas distribution as indicated on the identification plate.
- The instructions are only applicable if the relevant country code is stated on the unit. If this is not the case, the gas technical information for the relevant country needs to be consulted and modifications discussed with the manufacturer.
- There will be air in the gas pipes when the unit is first used. The gas pipes therefore need to be purged first.
- Ignite the fire according to operating instructions and check whether the burner flame is uniform. After the unit has been used for the first time, you should remove any deposits resulting from running/burning in the paint, using an appropriate glass cleaner.
- This appliance features an Oxypilot atmospheric sensing device. The Oxypilot will shut down the appliance if an unacceptable amount of harmful products of combustion accumulate. Under no circumstances should the Oxypilot be altered or bypassed in anyway. If after a period of use the appliance shuts down for no apparent reason, the consumer should be informed to stop using the appliance immediately until it has been fully checked.
- Normal adventitious ventilation should provide a suitable amount required for this appliance. If there are any forced ventilation systems adjacent to the installation (i.e. cooker extraction hoods) then additional ventilation may be required in accordance with national, regional and local standards and regulations.
- A fireguard complying with BS 8423 should be fitted for the protection of young children, the elderly or the infirm.
- The unit must be cleaned and inspected annually by a competent person.

Distance to flammable materials:

- Furniture, curtains etc. = 1200mm
- Flooring (without using a hearth) = 300mm
- Flooring (using a hearth with a minimum depth of 300mm) = 140mm

IMPORTANT: Gas fires become hot when they are in operation. After installation the glass surface is considered an active zone. The glass surface can become very hot. CARE SHOULD BE TAKEN at all times with supervision of children and the infirm. Gas fires must not be on or placed against flammable materials (curtains etc.). Never install the unit against or within a flammable wall.

NOTE: Construction material for chimney breasts, fireplaces and mantles etc. must be made of non-combustible material. Heat resistant plaster and board material should be use if required. This also applies to floors and ceilings. Never use flammable materials near the unit in compliance with the above requirements. If in doubt, consult your dealer.

3.0 CHIMNEY & FLUE PREPARATION

3.1 Preparation

- If the existing chimney was previously used for burning solid fuel, the flue must be swept clean prior to installation.
- A chimney draw of approximately 5 pascals is sufficient to run the appliance. If the chimney draft is greater than 20 pascals it is recommended that steps are taken to reduce the draft.

3.2 Installation of flue liner

For optimum performance we recommend that the chimney is lined with a 100mm diameter stainless steel gas flue liner. Proprietary terminals must comply with BS715 or BS1289. Any terminal or termination must be positioned in accordance with BS5440 Part 1 to ensure that the products of combustion can be safely dispersed into the outside atmosphere. To connect the gas flue liner directly to the appliance follow the steps below and refer to **Appendix 1**.

- Remove the baffle plate **(1)** by loosening the two screws. The closure plate will now be visible **(2)**.
- Remove the closure plate by unscrewing the 3 screws. The flue connector will now be visible **(3)**.
- Remove the flue connector by unscrewing the four screws.
- Slide the stainless steel flue liner into the flue connector **(4)** and secure with a self tapping screw.
- Slide the flue connector (including the flue liner) upwards and into the top of the combustion chamber **(5)**. If a restrictor plate is required **(6)** now is the time to install it. There are two sizes of restrictor plates; 50mm and 70mm. For chimneys with a height of 3-6 metres the 50mm plate should be used. For chimneys with a height of 6 metres or above the 70mm plate should be used.
- Replace the closure plate.
- Replace the baffle plate.

3.3 Finished fireplace opening

There are two ways in which this appliance may be installed: a conventional style fireplace with a surround and hearth; or elevated as a 'hole in the wall' type installation. In both scenarios the following aperture must be created as a finished fireplace opening to accommodate the appliance within the chimney. When installing as a conventional style fireplace, ensure that dimension AA allows for the clearance of the combined height and the hearth and bottom slip.

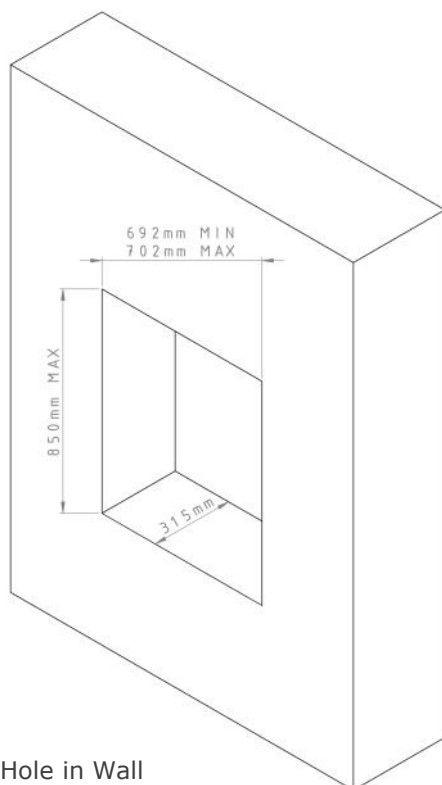

Hole in Wall

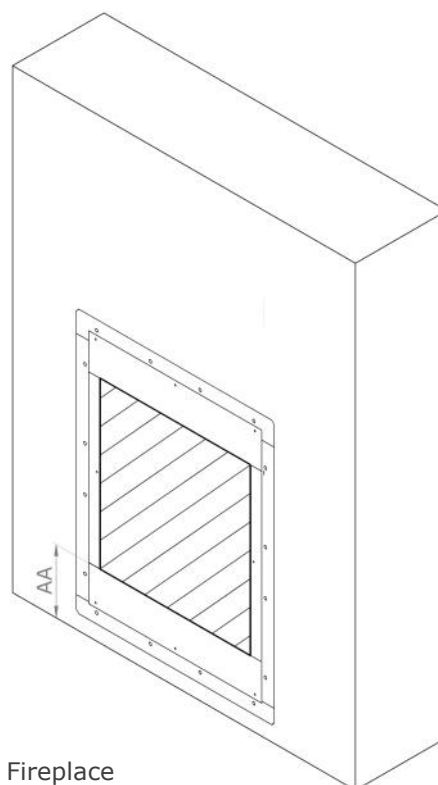

Fireplace

4.0 INSTALLING THE APPLIANCE

4.1 Connecting the gas lines

You can determine where the gas pipes will be placed depending on the positioning of the appliance. Ensure control equipment is not twisted during installation and there is no excessive tension. Accessibility of various connection points in relation to components need to be maintained. After installation, check the connections for gas leakage. Use a 3/8" gas tap in the main gas supply. **Ensure the gas pipes are dirt-and sand-free.** The gas connection should be done without any excessive tension in the tubes etc. This prevents any damage occurring to the gas control equipment.

4.2 Preparation and installation (see Appendix 2)

- Remove the packaging and check the unit for possible damage.
- Place the unit on a stable surface. **Do not** place the unit on its back/side!
- Place the unit at the installation location.
- Carefully remove the glass in order to take the additional parts out of the unit. To do this:
 - Remove the bottom glass retainer located against the bottom edge of the glass **(1)**.
 - Loosen the 2 screws holding the top glass retainer and remove **(2)**.
 - Place the suction cup (s) in the middle of the glass and remove the glass by GENTLY moving it first upwards and then the lower edge of the panel very carefully and slowly pulling toward you. Place the glass in a safe place where the window can not be broken or damaged.

IMPORTANT: If the removed glass panel shows any signs of damage (scratches and/or damaged edges) do not use the glass and contact the supplier.

- Next, take all the packaged components out of the unit and check to make sure they are not damaged or broken.
- Remove the burner and burner tray from the convection box. To do this:
 - Remove the decorative plate that sits around the burner by lifting upwards **(3)**.
 - Remove the burner by unscrewing 2 screw and lifting out **(4)**.
 - Remove the tray by unscrewing 4 screws and lifting out **(5)**.
- If necessary (e.g. installing with a fireplace mantle and hearth), remove the bottom flange from the convection box.
- Apply the adhesive foam seals to the rear of the combustion box outer flanges. Ensure that there is no gap between the foam seals where they meet. It is important that the bottom of the side flanges are sealed.
- The adjustable feet can be altered to refine the height of the appliance.
- Open up the required breakout slot at the rear of the convection chamber to allow entry of the gas supply pipe.
- Position the appliance into the fireplace opening and secure to the wall using the holes on the convection box flanges. Ensure a good seal is made between the appliance and the wall and that the correct type of screws and wall plugs are used (not supplied).

4.3 Installing the gas control GV60 (see Appendix 2)

The main gas connection has a pipe nipple 3/8" connection **(6)**. On this connection a compression fitting with copper tubing may be used.

4.4 I.O. switch

The I.O. switch can be accessed by removing the bottom glass retainer. This can be used to turn off the appliance when the batteries of the remote control have expired. It is also possible to turn off the I.O. switch during long periods of non-use to preserve the batteries.

4.5 Battery pack

To replace the batteries on the gas control, first lift our the bottom glass retainer. This has the battery pack attached to it. Replace the batteries and return the bottom glass retainer to its installed position.

5.0 PLACEMENT OF THE CERAMIC LOG SET

5.1 Natural Gas G20

Distribute one layer of the supplied granulate evenly over the burner and decorative plate. The opening around the burner must be kept free of glowing material. The ember flakes can be broken into smaller pieces and scattered randomly for decoration.

5.2 LPG G30-31

Distribute one layer of the supplied vermiculite evenly over the burner and one layer of the supplied granulate over the decorative plate. The opening around the burner must be kept free of glowing material. The ember flakes can be broken into smaller pieces and scattered randomly for decoration.



IMPORTANT: The opening around the burner must be kept free from glowing material. Too much placed glowing material can affect the combustion process.

5.3 Ceramic log placement

Place the logs carefully and in the correct order as shown. Not doing so can seriously affect the flame picture or cause sooting.

After placing the ceramic log set, replace the glass window by carefully using the suction cup to place the glass into the appliance and re-fit the top and bottom glass retainers.

NOTE: Before you replace the glass be sure to check if a restrictor plate must be used.



5.0 PLACEMENT OF THE CERAMIC LOG SET



NOTE: When installing the log set and the various glowing materials and accessories, the following must be taken into account:

- A:** No glowing material in or on the pilot burner.
- B:** Prevent any ceramic material from touching the glass seals. Remove this if necessary as it can damage the glass.
- C:** Slot / opening between burner and mesh deco plate must be kept free of glowing material. Too much placed glowing material can affect the combustion process.

6.0 TECHNICAL DETAILS GV60

Gas valve type: Mertik GV60
 Burner control: B6R R8U
 Ignition: Remote control operation and Piezo ignition
 Gas connection: 3/8 " (External)
 Pilot flame: Oxi pilot

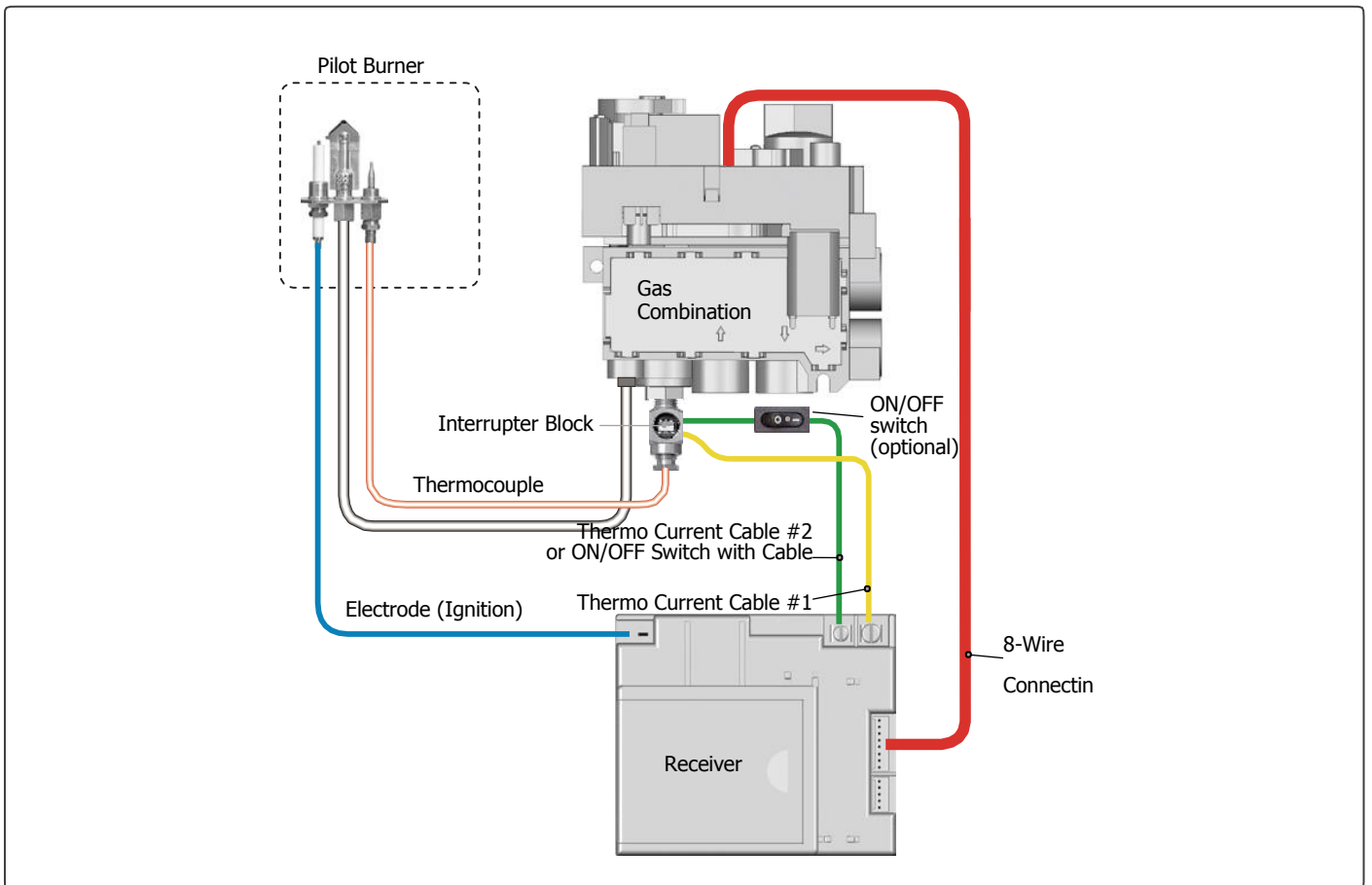
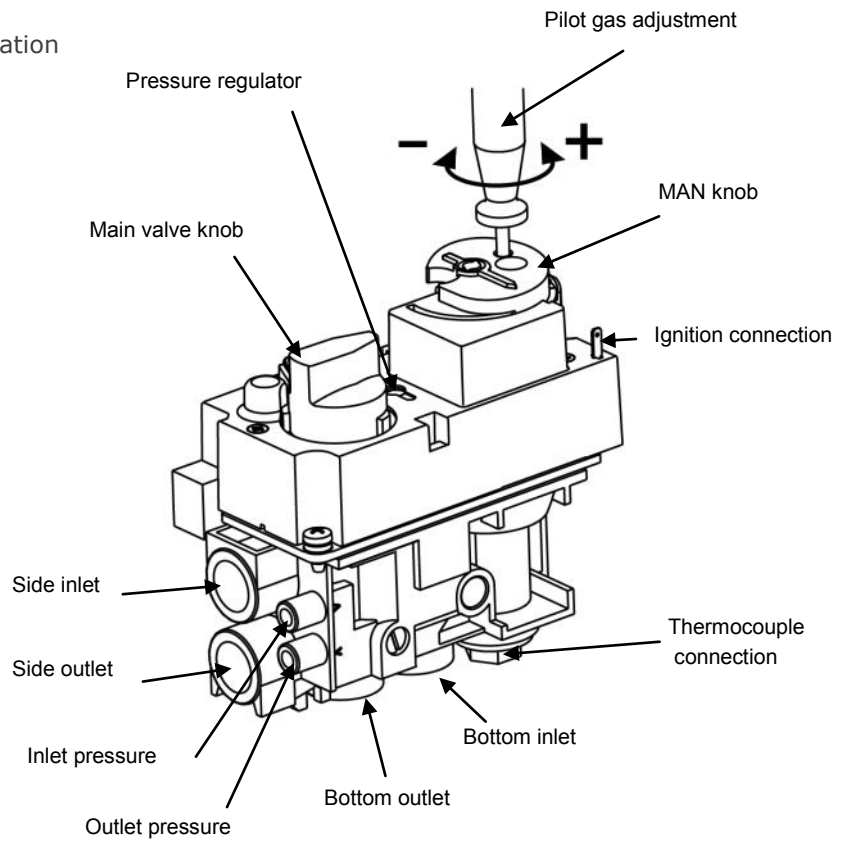

7.0 INSTRUCTIONS FOR MERTIK MAXITROL GV60 GAS CONTROL

IMPORTANT: Do not start up the unit if the glass is not present or broken.

Ensure that the fuel supplied to the unit is clean and free from particles and moisture.

Before a gas supply pipe (new or existing) is connected to the main gas pipe at the gas meter and to the gas control block of the unit, clean and dry compressed air should be blown through it. Cut copper pipes as well as aluminium pilot pipes must be deburred and blown clean before they are connected. The dust filter at the connection to the gas control block will only filter out the coarsest dirt from the system. Fine particles are still able to reach the inside and may damage and/or adversely affect regulation in the gas control block.

Heat, moisture and dust are a threat to all electronic components.

Protect the electronic gas control *until* all construction, plastering and paintwork has been completed. If such work cannot be avoided, then protect the control against dirt and moisture penetration by using, for example plastic film.

IMPORTANT: Electronic components will become permanently faulty when exposed to temperatures higher than 60°C. Standard AA batteries will crack open at temperatures >54°C and the battery contents will damage the electronic switches located underneath. Batteries last longest at <25°C. At >50°C the life span is around 23 weeks, this makes the use of the gas fire unnecessarily expensive.

Only install the gas control block and receiver as pre-installed at the factory.

Remember that components may have to be replaced or that repairs may have to be performed at a later date. This may be more difficult if the control is installed using a method that is different from the instructions provided here.

Only place the batteries *after* wiring to the receiver, gas control block and pilot set is connected.

Premature connection to the energy source may damage the control's CPU (central processor).

Ensure that the ignition cable is not near the antenna wire and that they do not cross each other.

The high voltage released at ignition may damage the sensitive receiver circuit. This may mean that the unit becomes less responsive or not responsive at all to handset commands.

NOTE: Do not tighten the contact breaker and the thermocouple connection too tightly on the gas control block or to each other. It is sufficient to tighten by hand and add a half a turn with an open-end spanner. Tightening too much will break the connection to the magnetic coil below and/or the insulation around the aluminium contact pin in the contact breaker. This may lead to the magnetic coil not opening the gas supply to the pilot and the unit not working.

Extend the supplied thermocouple with just the original extension (available from your supplier).

Unauthorized extension of the thermocouple has the effect of stress reduction, thereby the magnetic coil can not be activated.

Prevent leakage of the ignition spark to other parts of the installation than the Ignition by the pilot.

Keep the ignition free of hull or other metal parts. If cable extension is used, see to it that connections are additionally insulated with a silicone grommet.

For automatic start via the transmitter, the receiver and the control the gas control valve should be switched.

The oval disk on the gas control block should be turned to the ON position. The **I/O** switch should be set to "**I**". The ignition must be connected to the receiver box at the terminal **SPARK**.

The transmitter's contains the thermostat sensor system.

The transmitter operates best at 2 to 3 m from the unit. Although the communication via short wave radio signals takes place, it is recommended that the transmitter in the 'visibility' of to lay the gas apparatus in a place where the user wants to experience a pleasant temperature. Place the hand transmitter in direct sunlight or other hot places. The thermostat measures the temperature and regulates the flame size of the gas in accordance.

Remove batteries only with the red ribbon which is under the battery, not with a metal tool.

Removing batteries with a metal object will permanently damage the electronic control.

8.0 TROUBLESHOOTING FLOW CHART - MERTIK GV60

No.	ACTION		POSSIBLE PROBLEM/CAUSE	SOLUTION
1.	Option: wall switch START: press ON button > wall switch works.	NO →	Bent pin on switch, or cable not operating properly.	Straighten pin, replace wall switch or cable.
1.	Manual transmitter START: press both buttons to start ignition sequence. Beep will occur each second.	NO →	Manual transmitter battery low.	Replace battery, 2x AAA 1.5V quality alkaline!
			Receiver batteries low.	Replace batteries, 2x AA 1.5V quality alkaline!
			Optional mains adapter not operating properly.	Check mains adapter.
			Check coding of transmitter and receiver.	Learn in new code, see instructions and label on receiver.
			Transmitter/receiver range limited.	1. Move antenna cable, see instructions. 2. Replace receiver.
			Optional wall switch / cabling not operating properly.	Replace wall switch / cabling.
			Receiver fuse blown (in older versions only).	Replace receiver.
	OK ↓			
2.	Magnet unit in gas valve is energised (audible click)	NO →	No beep	Impulse magnet not operating properly. Replace gas valve.
		NO →	3 short beeps	Receiver batteries low. Replace batteries, 4x 1.5V AA quality alkaline!
		NO →	1 long beep	ON/OFF switch on gas valve in OFF position. Set switch to ON.
			8-wire cable between receiver and gas valve defective / poor contact.	Check cable, especially in case of plug connection.
			Switch cable disconnected.	Check switch cable.
			Motor not operating properly.	Replace gas valve.
			Micro switch on gas valve not operating properly.	Replace gas valve.
	OK ↓			

8.0 TROUBLESHOOTING FLOW CHART - MERTIK GV60

No	ACTION	POSSIBLE PROBLEM/CAUSE	SOLUTION
----	--------	------------------------	----------

3.	<div style="border: 1px solid black; padding: 5px; width: 150px; height: 100px; display: flex; flex-direction: column; justify-content: space-around;"> <div>Continuous spark</div> <div>Spark will occur each second.</div> </div>	NO →	Ignition components not operating properly.	Check connection between cable & IGN electrode. Check IGN electrode spark gap. Check IGN electrode for discharge to ground (break in ceramic). Check IGN cable for damage Increase distance between IGN cable and all metal parts. Check that spark does not discharge to ground at location of spark plug connection. Shorten cable if possible. If applicable, provide extra insulation with silicon hose etc.
		NO →	IGN sequence stops, no pilot flame. No reaction to transmitter command (receiver does not react).	Press RESET button, see instructions. Add ground wire between pilot burner and gas valve. Do not coil the IGN cable. Shorten IGN cable if possible.
		NO →	IGN sequence stops, no pilot flame. Transmitter command is possible.	IGN sequence stops, no pilot flame. Transmitter command is possible.

OK ↓

4.	<div style="border: 1px solid black; padding: 5px; width: 150px; height: 30px;">Pilot lit.</div>	NO →	TC and SW cable reversed.	Check connection of cable to receiver and interrupter, see fig. 1.
		NO →	Impulse magnet not operating properly.	Replace gas valve.
		NO →	Short between interrupter and SW cable.	Check connection to interrupter.
		NO →	No gas magnet unit drops after 30 second audible count).	Check gas supply to gas valve.

OK ↓

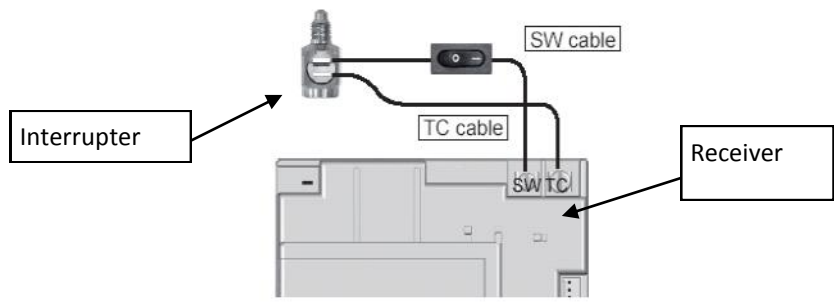

Figure 1

5.	<div style="border: 1px solid black; padding: 5px; width: 150px; height: 30px;">Sparkling stops after pilot is lit</div>	NO →	Short between interrupter and TC cable.	Check connection to interrupter, see fig. 1
		NO →	Electronic measuring amplifier defective.	Replace receiver.

OK ↓

8.0 TROUBLESHOOTING FLOW CHART - MERTIK GV60

No	ACTION		POSSIBLE PROBLEM/ CAUSE	SOLUTION
6.	<div style="border: 1px solid black; height: 100px; width: 100%; display: flex; align-items: center; justify-content: center;"> Motor turns to main gas and pilot stays lit. </div>	NO →	Resistance in thermo current circuit too high.	Check cables and connections in thermo current circuit.
		Solenoid drops (audible click)	Not enough heat on thermocouple.	Check position of pilot to thermocouple and intensity of pilot flame.
		Low voltage from thermocouple.	Check connections and, if necessary, replace thermocouple. Do not over tighten the connections!	
		Short because thermocouple end is damaged.	Replace thermocouple, do not overtighten the connections!	
	<div style="border: 1px solid black; height: 100px; width: 100%; display: flex; align-items: center; justify-content: center;"> OK ↓ </div>	NO →	IGN sequence stops. No reaction to transmitter command (receiver does not react).	Press RESET button, see instructions.
		Add ground wire between pilot burner and gas valve.		
		Do not coil the IGN cable. Shorten IGN cable if possible.		
7.	<div style="border: 1px solid black; height: 30px; width: 100%; display: flex; align-items: center; justify-content: center;"> Main burner is lit. </div>	NO →	Gas valve manual knob in "MAN" position.	Turn knob to "ON" position.
	<div style="border: 1px solid black; height: 100px; width: 100%; display: flex; align-items: center; justify-content: center;"> OK ↓ </div>	NO →	Too much / too little air flow / draft at pilot, blows out or is smothered.	Check whether restriction plate has been correctly applied in unit, see instructions. Poor flue location, check correctness of layout and connections.
		OK ↓		
8.	<div style="border: 1px solid black; height: 30px; width: 100%; display: flex; align-items: center; justify-content: center;"> Main burner stays lit. </div>	NO →	Receiver batteries low.	Replace batteries, 1.5V AA quality alkaline!
9.	<div style="border: 1px solid black; height: 30px; width: 100%; display: flex; align-items: center; justify-content: center;"> Magnet unit drops while motor turns. 3 beeps. </div>	NO →	Short between TC and SW cable.	Check connection to interrupter block.
	<div style="border: 1px solid black; height: 30px; width: 100%; display: flex; align-items: center; justify-content: center;"> System can be switched OFF via remote control. </div>	NO →	System can be switched OFF via ON/OFF switch.	Replace gas valve.
	<div style="border: 1px solid black; height: 30px; width: 100%; display: flex; align-items: center; justify-content: center;"> YES ↓ OK </div>	YES ↓ OK		

9.0 PROBLEMS AND POSSIBLE SOLUTIONS

NOTE: Please first check if all guidelines were followed before attempting to solve any problems with the unit.

IMPORTANT: Solving problems with your unit, whether gas related or electrical, must always be performed by a qualified technician.

SYMPTOM	ACTION TO BE TAKEN
The pilot flame will not light after repeated ignition.	<ol style="list-style-type: none"> 1. There is air in the pipes if you switch the unit on for the first time or after a service. It will take a little while until all the air has flowed out of the pipes and gas flows through that can be ignited. Take it away and try to switch the pilot flame on several times in order to allow the air to escape. 2. See whether the gas pipe to the unit is open and if there is sufficient gas pressure to the unit. 3. Check whether there are sparks between the spark electrode and the pilot. If there are no sparks: <ol style="list-style-type: none"> a) Check whether the connection between the electrode and the ignition is broken or faulty. b) Check whether the spark short circuits at another point or jumps. c) Check whether the electrode is broken.
The pilot flame will not remain alight after ignition.	<ol style="list-style-type: none"> 1. Check whether the pilot flame is large enough to burn around the thermocouple. If the flame is too small, you need to check the gas feed pressure. If the size of the pilot flame cannot be adjusted, there may be an obstruction in the pilot. 2. Check whether the thermocouple interrupter is connected to the gas valve properly. 3. Check that the gas valve is not faulty. 4. Check whether the restriction plate has been placed according to instructions
The main burner goes out when the unit is warm.	<ol style="list-style-type: none"> 1. This can be a normal effect of the thermostat. Check whether the pilot flame is able to heat the thermocouple adequately. If the pilot flame is too small then the gas pipe or the pilot flame adjustment need to be checked. 2. Check whether the restriction plate has been placed according to instructions.
Soot deposits on the glass.	<ol style="list-style-type: none"> 1. Check whether the lava split is lying on the burner in the correct manner. 2. Check if the pilot burner is free from burner filling. 3. Check whether there is any blockage in the burner openings. 4. Check if the flue tube is functioning correctly and if the flue tube is not hindered or blocked. 5. Check the pipe pressure.
Sharp blue flames that are released by the burner or a pilot that burns too wildly.	<ol style="list-style-type: none"> 1. Check whether the restriction plate has been used.
Weak (stifling) pilot flame.	<ol style="list-style-type: none"> 1. Check the pilot burner pressure or duct pathway.
Main burner will not burn after the pilot burner is functioning.	<ol style="list-style-type: none"> 1. Check if the motor button turns and whether the batteries are empty. 2. Possible defect in the gas block. 3. Check whether the pilot flame ignites the burner well. 4. Check that the burner opening is not blocked.

APPENDIX 1 - CONNECTION TO FLUE LINER

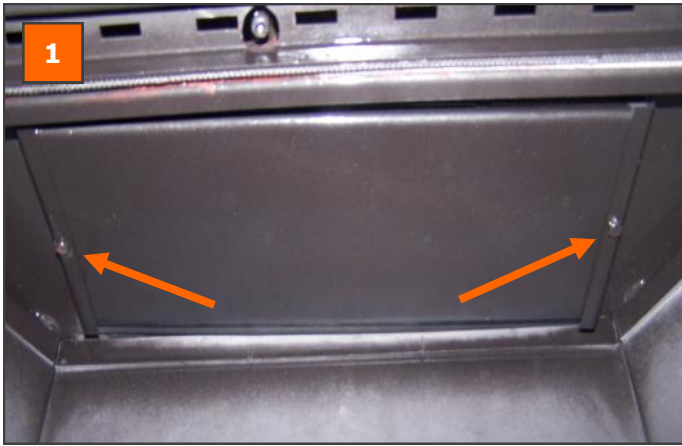

APPENDIX 2 - INSTALLING THE APPLIANCE

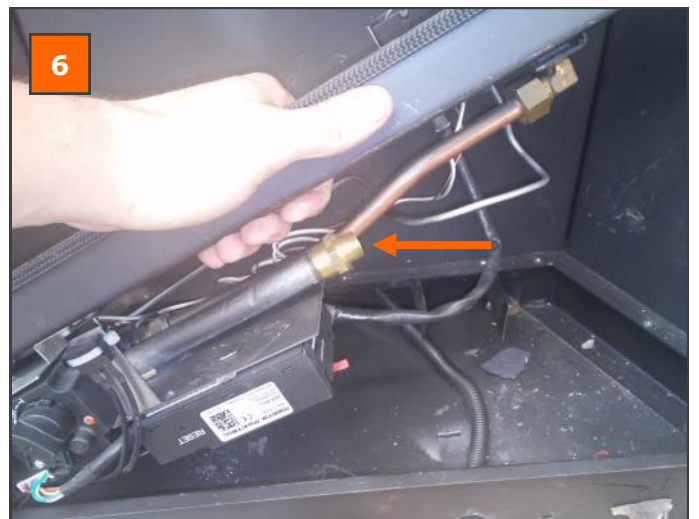
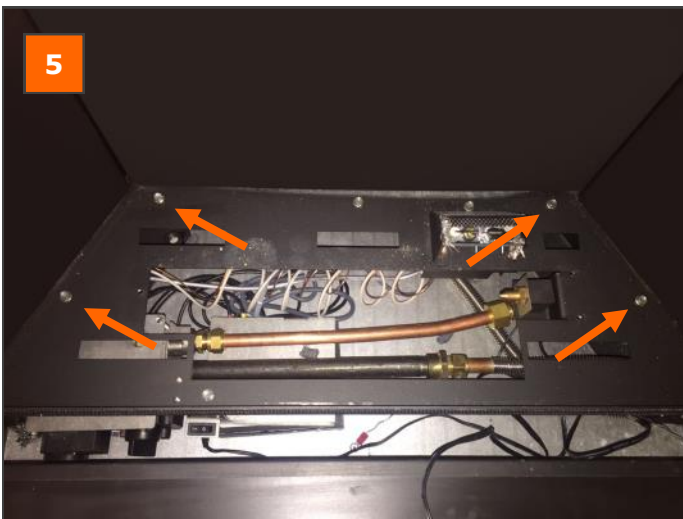
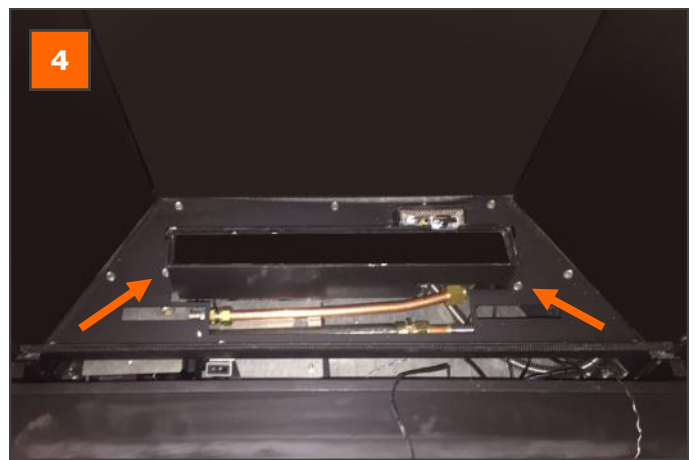
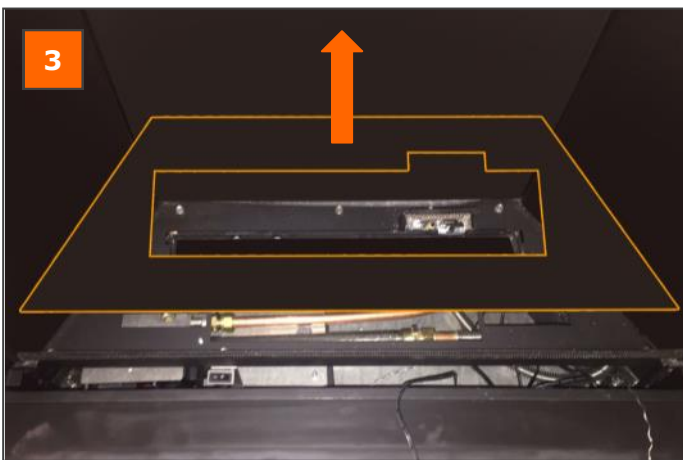

VISION
trimline

Brought to you by

 **PERCYDOUGHTY**

Imperial Point
Express Trading Estate
Stone Hill Road
Farnworth
Bolton
BL4 9TN

Tel: 01204 868 550 Fax: 01204 868 551 Email: sales@percydoughty.com

www.visionfires.co.uk