

VISION  
trimline



PRICE GUIDE **2022**



TRIMLESS.

## TL38 TRIMLESS.

With Lamel Chamber

£4199

**Optional Extras:**

Pebbles - £399

Remote Control Wall Mount - £49

Wall Switch - £149

ARG - £4619

WIFI Kit - £399

Mains Adaptor - £99

Domotica Control - £59.40



## TL46 TRIMLESS.

With Flat Steel Chamber

£2219

**Optional Extras:**

Remote Control Wall Mount - £49

Wall Switch - £149

WIFI Kit - £399

Mains Adaptor - £99

Domotica Control - £59.40





## TL63H TRIMLESS.

With Flat Steel Chamber

£4619

### Optional Extras:

- Black Glass Panel - £799
- Interior Brick Chamber - £499
- Reeded Chamber - £399
- LED Glowing Fuel Bed - £499
- Wall Bracket - £149
- Remote Control Wall Mount - £49
- Wall Switch - £149
- ARG - £5039
- WIFI Kit - £399
- Mains Adaptor - £99
- Domotica Control - £59.40
- Wide Trims - £217.80



## TL73 TRIMLESS.

With Lamel Chamber

£3679

### Optional Extras:

- Pebbles - £399
- Remote Control Wall Mount - £49
- ARG - £3989
- WIFI Kit - £399
- Wall Switch - £149
- Mains Adaptor - £99
- Domotica Control - £59.40
- Wide Trims - £217.80



## TL73H TRIMLESS.

With Flat Steel Chamber

£3779

### Optional Extras:

- Pebbles - £399
- Lamel Chamber - £199
- Black Glass Panel - £749
- Grey Chamber - £599
- Deco Brick Chamber - £599
- Deco Tile Chamber - £249
- Remote Control Wall Mount - £49
- Wall Switch - £149
- Mains Adaptor - £99
- ARG - £4409
- WIFI Kit - £399
- Domotica Control - £59.40
- Wide Trims - £217.80



## TL83 TRIMLESS.

With Flat Steel Chamber

£ 4519

### Optional Extras:

- Black Glass Panel - £799
- Interior Grey Brick Chamber - £699
- Black Groove Chamber - £599
- LED Glowing Fuel Bed - £399
- Wall Bracket - £99
- Leg Extension - £99
- Remote Control Wall Mount - £49
- Wall Switch - £149
- Mains Adaptor - £99
- ARG - £4939
- WIFI Kit - £399
- Domotica Control - £59.40



## TL100 TRIMLESS.

With Lamel Chamber

£3569 (NG)

£4199 (LPG)

### Optional Extras:

- Pebbles - £499
- Carrara - £89
- Basalt - £89
- Black Glass Panel - £529
- Remote Control Wall Mount - £49
- Wall Switch - £149
- Mains Adaptor - £99
- ARG - £4099 (NG)
- £4829 (LPG)
- WIFI Kit - £399
- Domotica Control - £59.40
- Wide Trims - £235.62



## TL100 SILHOUETTE.

With Lamel Chamber

£3569 - (NG)

£4199 - (LPG)

£99 - Silhouette Steel Trim

### Optional Extras:

- Pebbles - £499
- Carrara - £89
- Basalt - £89
- Black Glass Panel - £529
- Remote Control Wall Mount - £49
- Wall Switch - £149
- Mains Adaptor - £99
- ARG - £4099 (NG)
- £4829 (LPG)
- WIFI Kit - £399
- Domotica Control - £59.40





## TL120 TRIMLESS.

With Lamel Chamber

£3989

### Optional Extras:

- Pebbles - £499
- Carrara - £89
- Basalt - £89
- Black Glass Panel - £599
- Wall Switch - £149
- Mains Adaptor - £99
- ARG - £5149
- WIFI Kit - £399
- Remote Control Wall Mount - £49
- Domotica Control - £59.40
- Wide Trims - £267.30



## TL140 TRIMLESS.

With Lamel Chamber

£4939

### Optional Extras:

- Pebbles - £499
- Carrara - £119
- Basalt - £119
- Black Glass Panel - £629
- Wall Switch - £149
- Mains Adaptor - £99
- ARG - £5679
- WIFI Kit - £399
- Remote Control Wall Mount - £49
- Domotica Control - £59.40
- Wide Trims - £295.02



## TL170 TRIMLESS.

With Lamel Chamber

£5249

### Optional Extras:

- Pebbles - £599
- Carrara - £129
- Basalt - £129
- Black Glass Panel - £749
- Wall Switch - £149
- Mains Adaptor - £99
- ARG - £5779
- WIFI Kit - £399
- Remote Control Wall Mount - £49
- Domotica Control - £59.40
- Wide Trims - £267.30





# TUNNEL.

## TL73H TUNNEL.

With Black Steel Chamber

£4619

**Optional Extras:**

Pebbles - £399

ARG - £5459

WIFI Kit - £399

Wall Switch - £149

Mains Adaptor - £99

Remote Control Wall Mount - £49

Domotica Control - £59.40

Wide Trims - £217.80



## TL83T TUNNEL.

With Lamel Chamber

£6509

**Optional Extras:**

Black Glass Panel - £249

Black Groove Chamber - £199

LED Glowing Fuel Bed - £399

Wall Bracket - £399

Wall Switch - £149

Mains Adaptor - £99

ARG - £7039

WIFI Kit - £399

Remote Control Wall Mount - £49

Domotica Control - £59.40



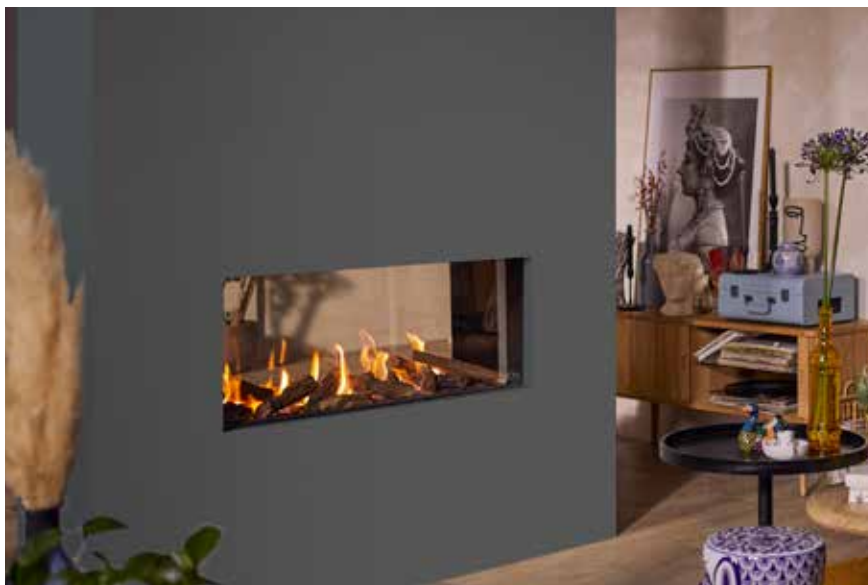

## TL100T TUNNEL.

With Flat Steel Chamber

£4099

### Optional Extras:

- Pebbles - £499
- Carrara - £89
- Basalt - £89
- ARG - £4829
- WIFI Kit - £399
- Remote Control Wall Mount - £49
- Wall Switch - £149
- Mains Adaptor - £99
- Domotica Control - £59.40
- Wide Trims - £161.30



## TL120T TUNNEL.

With Flat Steel Chamber

£4829

### Optional Extras:

- Pebbles - £499
- Carrara - £89
- Basalt - £89
- ARG - £5669
- WIFI Kit - £399
- Remote Control Wall Mount - £49
- Wall Switch - £149
- Mains Adaptor - £99
- Domotica Control - £59.40
- Wide Trims - £267.30



## TL140T TUNNEL.

With Flat Steel Chamber

£6089

### Optional Extras:

- Pebbles - £499
- Carrara - £119
- Basalt - £119
- ARG - £6719
- WIFI Kit - £399
- Remote Control Wall Mount - £49
- Wall Switch - £149
- Mains Adaptor - £99
- Domotica Control - £59.40
- Wide Trims - £295.02



## ROOM DIVIDER.

### TL73RD ROOM DIVIDER.

With Flat Steel Chamber

£5249 (NG)

£5669 (LPG)

**Optional Extras:**

Pebbles - £399

ARG - £5669 (NG & LPG)

WIFI Kit - £399

Remote Control Wall Mount - £49

Wall Switch - £149

Mains Adaptor - £99

Domotica Control - £59.40

Wide Trims - £295.02



### TL83RD ROOM DIVIDER.

With Flat Steel Chamber

£6089

**Optional Extras:**

Black Glass Panel - £249

Black Groove Chamber - £199

LED Glowing Fuel Bed - £399

ARG - £6829

WIFI Kit - £399

Remote Control Wall Mount - £49

Wall Switch - £149

Mains Adaptor - £99

Domotica Control - £59.40







## TL85RD ROOM DIVIDER.

With Lamel Chamber

£5679

### Optional Extras:

Pebbles - £399

Carrara - £99

Basalt - £79

ARG - £6619

WIFI Kit - £399

Remote Control Wall Mount - £49

Wall Switch - £149

Mains Adaptor - £99

Domotica Control - £59.40

Wide Trims - £275.92





# CORNER.

## TL38C CORNER.

With Lamel Chamber

£4199

**Optional Extras:**

- Pebbles - £399
- ARG - £4619
- WIFI Kit - £399
- Remote Control Wall Mount - £49
- Wall Switch - £149
- Mains Adaptor - £99
- Domotica Control - £59.40
- Wide Trims - £205.92



## TL63C CORNER.

With Lamel Chamber

£4939

**Optional Extras:**

- Black Glass Panel - £599
- Interior Brick Chamber - £399
- Reeded Chamber - £299
- LED Glowing Fuel Bed - £499
- Wall Bracket - £149
- ARG - £5459
- WIFI Kit - £399
- Remote Control Wall Mount - £49
- Wall Switch - £149
- Mains Adaptor - £99
- Domotica Control - £59.40





## TL83C CORNER.

With Flat Steel Chamber

£ 4729

Optional Extras:

- Black Glass Panel - £699
- Interior Grey Chamber - £599
- Black Groove Chamber - £499
- LED Glowing Fuel Bed - £399
- ARG - £5249
- WIFI Kit - £399
- Remote Control Wall Mount - £49
- Wall Switch - £149
- Mains Adaptor - £99
- Domotica Control - £59.40



## TL100 CORNER.

With Lamel Chamber

£4199

**Optional Extras:**

- Pebbles - £499
- Carrara - £89
- Basalt - £89
- Black Glass Panel - £499
- WIFI Kit - £399
- Remote Control Wall Mount - £49
- Wall Switch - £149
- Mains Adaptor - £99
- Domotica Control - £59.40
- Wide Trims - £275.22



## TL120 CORNER.

With Lamel Chamber

£5149

**Optional Extras:**

- Pebbles - £499
- Carrara - £89
- Basalt - £89
- Black Glass Panel - £499
- ARG - £5679
- WIFI Kit - £399
- Remote Control Wall Mount - £49
- Wall Switch - £149
- Mains Adaptor - £99
- Domotica Control - £59.40
- Wide Trims - £314.82



## TL140 CORNER.

With Lamel Chamber

£5669

### Optional Extras:

- Pebbles - £499
- Carrara - £119
- Basalt - £119
- Black Glass Panel - £599
- WIFI Kit - £399
- Remote Control Wall Mount - £49
- Wall Switch - £149
- Mains Adaptor - £99
- Domotica Control - £59.40
- Wide Trims - £334.62



## TL2050 ON THE CORNER.

With Anthracite Steel Panel

£6089

### Optional Extras:

- ARG - £6509
- WIFI Kit - £399
- Remote Control Wall Mount - £49
- Wall Switch - £149
- Mains Adaptor - £99
- Domotica Control - £59.40





# PANORAMIC.



## TL38P PANORAMIC.

With Lamel Chamber

£4409

**Optional Extras:**

- Pebbles - £399
- ARG - £4729
- WIFI Kit - £399
- Remote Control Wall Mount - £49
- Wall Switch - £149
- Mains Adaptor - £99
- Domotica Control - £59.40



## TL63P PANORAMIC.

With Flat Steel Chamber

£5149

**Optional Extras:**

- Black Glass Panel - £449
- Interior Brick Chamber - £279
- Reeded Chamber - £199
- LED Glowing Fuel Bed - £499
- Wall Bracket - £149
- ARG - £5669
- WIFI Kit - £399
- Remote Control Wall Mount - £49
- Wall Switch - £149
- Mains Adaptor - £99
- Domotica Control - £59.40

## TL83P PANORAMIC.

With Flat Steel Chamber

£4829

### Optional Extras:

Interior Grey Chamber - £399  
Black Glass Panel - £499  
Black Groove Chamber - £399  
LED Glowing Fuel Bed - £399  
ARG - £5459  
WIFI Kit - £399  
Remote Control Wall Mount - £49  
Wall Switch - £149  
Mains Adaptor - £99  
Domotica Control - £59.40



## TL100P PANORAMIC.

With Lamel Chamber

£4299

### Optional Extras:

Pebbles - £499  
Carrara - £89  
Basalt - £89  
Black Glass Panel - £399  
ARG - £4829  
WIFI Kit - £399  
Remote Control Wall Mount - £49  
Wall Switch - £149  
Mains Adaptor - £99  
Domotica Control - £59.40  
Wide Trims - £314.82



## TL120P PANORAMIC.

With Lamel Chamber

£5879

### Optional Extras:

Pebbles - £499  
Carrara - £89  
Basalt - £89  
Black Glass Panel - £499  
ARG - £6619  
WIFI Kit - £399  
Remote Control Wall Mount - £49  
Wall Switch - £149  
Mains Adaptor - £99  
Domotica Control - £59.40  
Wide Trims - £334.62







## TL140P PANORAMIC.

With Lamel Chamber

£5669

### Optional Extras:

- Pebbles - £499
- Carrara - £119
- Basalt - £119
- Black Glass Panel - £499
- ARG - £6199
- WIFI Kit - £399
- Remote Control Wall Mount - £49
- Wall Switch - £149
- Mains Adaptor - £99
- Domotica Control - £59.40
- Wide Trims - £354.42





## TL70 SLIMLINE.

### TL70SL.

With Lamel Chamber

With Mains Adaptor, Flue Terminal & Guard

£2319

**Optional Extras:**

Black Glass Panel - £249

Vermiculite Panels - £149

Vermiculite Chamber Upper - £199

Vermiculite Chamber Lower - £199

ARG - £2519

WIFI Kit - £399

Remote Control Wall Mount - £49

Domotica Control - £59.40



### INTEGRATED HEAT BOX.

£699

To suit TL70SL only





## TL70SL & RADLEY SUITE.

Portuguese Limestone Mantel to Suit TL70SL

£3569

### Optional Extras:

- Black Glass Panel - £249
- Vermiculite Panels - £149
- Vermiculite Chamber Upper - £199
- Vermiculite Chamber Lower - £199
- ARG- £3779
- WIFI Kit - £399
- Remote Control Wall Mount - £49
- Domotica Control - £59.40



## TL70SL & RICO SUITE.

With Lamel Chamber

£3569

### Optional Extras:

- Black Glass Panel - £249
- Vermiculite Panels - £149
- Vermiculite Chamber Upper - £199
- Vermiculite Chamber Lower - £199
- ARG- £3779
- WIFI Kit - £399
- Remote Control Wall Mount - £49
- Domotica Control - £59.40



## TL70SL & PANACEA SUITE.

With Lamel Chamber

£4199

### Optional Extras:

- Black Glass Panel - £249
- Vermiculite Panels - £149
- Vermiculite Chamber Upper - £199
- Vermiculite Chamber Lower - £199
- ARG - £4519
- WIFI Kit - £399
- Remote Control Wall Mount - £49
- Domotica Control - £59.40



## TL70SL & HAMPTON SUITE.

With Lamel Chamber

£2619

### Optional Extras:

Black Glass Panel - £249

Vermiculite Panels - £149

Vermiculite Chamber Upper - £199

Vermiculite Chamber Lower - £199

ARG- £2899

WIFI Kit - £399

Remote Control Wall Mount - £49

Domotica Control - £59.40





## GEMSTONE SERIES.



### ZIRCON.

With Steel Chamber

£3259

**Optional Extras:**

- Wifi Kit - £399
- Wall Switch - £149
- Mains Adaptor - £99
- Remote Control Wall Mount - £49
- Domotica Control - £59.40



### TOURMALINE.

With Black Steel Chamber

£3779

**Optional Extras:**

- LED Unit - £599
- Black Glass - £549
- Wood Stool - £499
- Fire Stool - £499
- ARG - £4099
- Wall Switch - £149
- Mains Adaptor - £99
- Remote Control Wall Mount - £49
- Wifi Kit - £399
- Domotica Control - £59.40



## QUARTZ.

With Lamel Chamber

£4409 (NG)

£4619 (LPG)

**Optional Extras:**

ARG- £4729 (NG)

ARG- £4729 (LPG)

Wall Switch - £149

Mains Adaptor - £99

Remote Control Wall Mount - £49

Wifi Kit - £399

Domotica Control - £59.40







## CONVENTIONAL FLUE.



### TL60CF TRIMLESS.

With Flat Steel Chamber  
Price Excludes Honed Granite Slips

£2419

**Optional Extras:**

Black Glass Panel - £599  
ARG - £2939  
Remote Control Wall Mount - £49  
Honed Granite Slips - £199



### TL60CF WOODBURY SUITE.

With Flat Steel Chamber  
£3629  
With TL60CF Fire, Woodbury Mantel  
and Portuguese Limestone or Honed  
Granite Slips.

**Optional Extras:**

Black Glass Panel - £599  
ARG - £4149  
Remote Control Wall Mount - £49



## SLIP SETS TO SUIT TL60CF.

POLISHED GRANITE  
SLIP SET\*

£199



AGEAN LIMESTONE  
SLIP SET\*

£199



HONED GRANITE  
SLIP SET\*

£199





IBERIAN LIMESTONE  
SLIP SET\*

£199



PORTUGUESE  
LIMESTONE  
SLIP SET\*

£199



HONED SLATE  
SLIP SET\*

£199

\*Prices Shown Includes Slip Set Only. (Price excludes Mantel, Hearth & Appliance)







## SLIP SETS TO SUIT TL73H.

BRUSHED STEEL  
& GRANITE  
SLIP SET\*

£ 199



POLISHED GRANITE  
SLIP SET\*

£ 199



HONED GRANITE  
SLIP SET\*

£199





AGEAN LIMESTONE  
SLIP SET\*

£199



NATURAL SLATE  
& GRANITE  
SLIP SET\*

£199



PORTUGUESE  
LIMESTONE  
SLIP SET\*

£199

\*Prices Shown Includes Slip Set Only. (Price excludes Mantel, Hearth & Appliance)



# EVERYTHING YOU NEED IN ONE PACKAGE.

We know the importance of keeping things simple. That's why every Vision Trimline fire comes complete with 'included extras' to help make your purchase as easy as possible.

As standard, all fires come complete with:

- Ecomax remote control
- Adjustable legs
- Control access door
- Convection vents
- Glowing embers
- Double Burner (DB) feature



## INTERIOR STYLING.

For that extra WOW factor, why not choose to upgrade to a black mirrored glass lining for your fire chamber and add a reflection to the fuel bed and flames to give a remarkable effect of added depth and detail.

If burning logs is not the look you are going for, then perhaps you would be more interested in an alternative fuel bed for your fire. The collection features a range of stunning options to choose from.

Lamel Chamber Panel



Black Groove Chamber Panel



Vermiculite Chamber Panel



Interior Grey Brick Chamber Panel



Black Glass Panel



Fire Brick Chamber Panel



Reeded Chamber Panel



High Definition Logs



Carrara Stones



White Pebbles



Basalt





# CONCENTRIC FLUE SYSTEMS.

Our concentric flue systems manufactured in the Netherlands by Holetherm are specifically designed for use with balanced flue gas fires.

We have a wide range of flue components and sizes to suit most configurations. Quick and easy to install our concentric flue is made from stainless steel and is fully weatherproof. Our concentric flue systems are backed by a 10 year conditional warranty\*.

\* Terms & Conditions apply



## UP & OUT PACKAGES

CODE	DESCRIPTION	SSP (INC.VAT)
0128047	TC FLUE PACK 1 (UP & OUT) 38 & 46 ONLY	£309
0128048	TC FLUE PACK 2 (UP & OUT) 100 & 150 ONLY	£420
0128049	TC FLUE PACK 3 (UP & OUT) 130 & 200 ONLY	£629

## STRAIGHT LENGTH

Available in three lengths which can be easily combined to achieve the required height for the installation. Each joint is firmly secured using the locking bands supplied.

CODE	PART	SIZE	DIA A	DIA B	L1	SSP (INC.VAT)
0127800	LENGTH 1000MM	100/150	100	150	1000	£109
0127900	LENGTH 1000MM	130/200	130	200	1000	£139
0127801	LENGTH 500MM	100/150	100	150	500	£89
0127901	LENGTH 500MM	130/200	130	200	500	£99
0127803	LENGTH 250MM	100/150	100	150	250	£79
0127903	LENGTH 250MM	130/200	130	200	250	£89

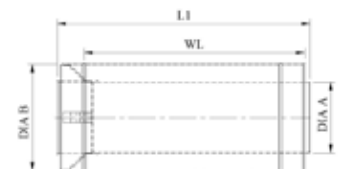

## ADJUSTABLE LENGTHS

This component is used to ensure any variation in length is achievable as outlined below. The adjustable lengths are non-load bearing and telescopic and a wall bracket must be used on the component directly above the chimney run. Extra insulation is included so that additional length can be filled.

Adjustable length 310 - 445mm

CODE	PART	SIZE	DIA A	DIA B	L1	SSP (INC.VAT)
0127804	ADJUSTABLE LENGTH	100/150	100	150	310 - 445	£99
0127904	ADJUSTABLE LENGTH	130/200	130	200	310 - 445	£119

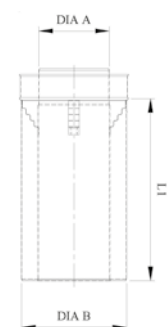

## INSPECTION LENGTH

CODE	PART	SIZE	DIA A	DIA B	SSP (INC.VAT)
0127845	INSPECTION LENGTH	100/150	100	150	£109
0127945	"	130/200	130	200	£129

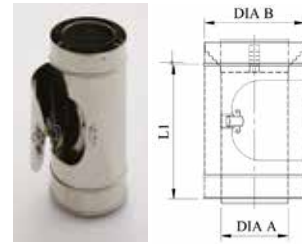

## ELBOWS

Available in four options and are used when a change in direction of a flue run is required. They can be easily rotated where required to achieve the required direction.

CODE	PART	SIZE	DIA A	DIA B	L1	L2	SSP (INC.VAT)
0127808	ELBOW 15°	100/150	100	150	72	42	£110
0127908	ELBOW 15°	130/200	130	200	90	52	£145
0127805	ELBOW 30°	100/150	100	150	72	42	£110
0127905	ELBOW 30°	130/200	130	200	90	52	£125
0127806	ELBOW 45°	100/150	100	150	72	42	£110
0127906	ELBOW 45°	130/200	130	200	90	52	£145
0127807	ELBOW 90°	100/150	100	150	72	90	£130
0127907	ELBOW 90°	130/200	130	200	87	106	£145

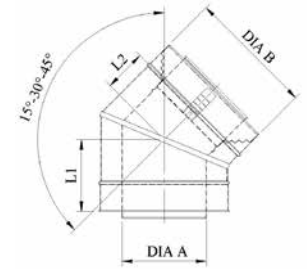

Pictured above is the 30° elbow

## INSPECTION ELBLOW

CODE	PART	SIZE	DIA A	DIA B	L1	L2	L3	L4	L5	SSP (INC.VAT)
01278071	INSPECTION ELBOW	100/150	100	150	72	90	44	145	150	£199
01279071	"	130/200	130	200	87	106	69	177	177	£215

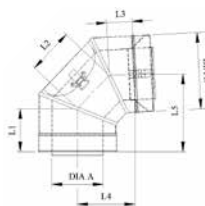

## WALL BAND

The wall band is used to support the flue system off of the wall.

CODE	PART	SIZE	DIA A	L1	L2	L3	SSP (INC.VAT)
01278171	WALL BAND	100/150	150	208	120-175	40	£35
01279171	"	130/200	200	206	148-203	40	£39

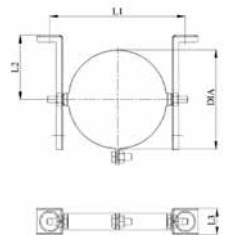

## ROOF SUPPORT

Pipe support for roof intersection

CODE	PART	SIZE	DIA A	L1	L2	L3	L4	L5	SSP (INC.VAT)
01278181	ROOF SUPPORT	100/150	150	385	311	225	158	76	£34
01279181	"	130/200	200	514	414	300	210	101	£45

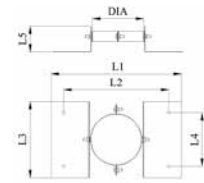

\* APPLIANCE ADAPTORS

## FIRESTOP PLATE

For use where flue system penetrates a wall or ceiling.

CODE	PART	SIZE	DIA	L1	L2	SSP (INC.VAT)
01278201	FIRESTOP PLATE	100/150	160	300	300	£19
01279201	"	130/200	210	350	350	£15

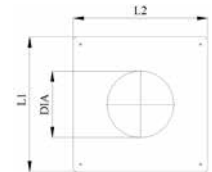

## FIRESTOP PITCHED

The pitched firestop for use on vaulted ceilings where the pitch of the ceiling is between 30 - 45 deg angle.

CODE	PART	SIZE	L1	L2	L3	SSP (INC.VAT)
01278211	FIRESTOP PITCHED	100/150	150	300	263	£19
01279211	"	130/200	200	350	288	£20

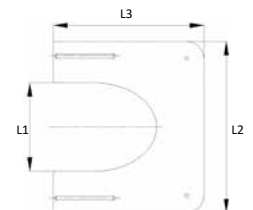

## FLASHINGS

Flashings are used to form a watertight seal when the chimney penetrates a slate or tiled roof available in lead or aluminium bases in a variety of sizes.

CODE	PART	SIZE	DIA	L1	L2	SSP (INC.VAT)
01278221	LEAD ROOF FLASHING 20" - 45"	100/150	160	150	700 X 800	£129
01279221	"	130/200	210	150	700 X 800	£169

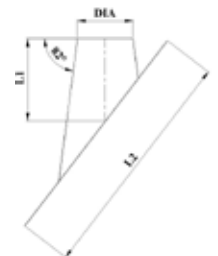

CODE	PART	SIZE	DIA	L1	L2	SSP (INC.VAT)
01278231	ROOF FLASHING 0" - 10"	100/150	160	190	550 X 550	£69
01279231	"	130/200	210	190	600 X 600	£69

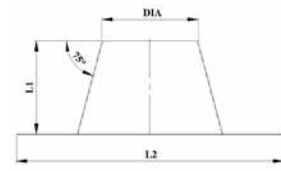
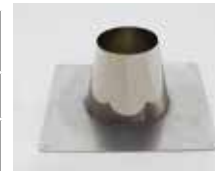

CODE	PART	SIZE	DIA	L1	L2	SSP (INC.VAT)
01278241	ROOF FLASHING PITCHED 5" - 25"	100/150	160	150	550 X 550	£89
01279241	"	130/200	210	150	600 X 600	£89

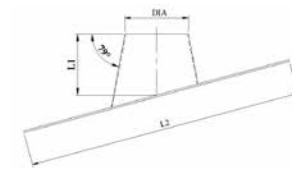

CODE	PART	SIZE	DIA	L1	L2	SSP (INC.VAT)
01278321	LEAD ROOF FLASHING 45" - 60"	100/150	160	150	700 X 800	£139
01279321	"	130/200	210	150	700 X 800	£199

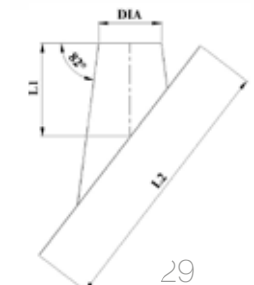



## STORM COLLAR

The storm collar is fitted to the flue run just after the installation passes through the roof and is fitted to the flue run just above the roof flashing using sealant and the nuts/bolts provided to give a weatherproof seal.

CODE	PART	SIZE	DIA A	DIA B	SSP (INC.VAT)
01278161	STORM COLLAR	100/150	100	150	£39
01279161	"	130/200	130	200	£39

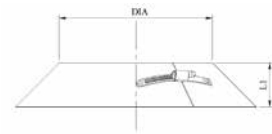

## CEILING SUPPORT

The ceiling support is supplied complete with a support collar and is for use where the flue system penetrates combustible floor.

CODE	PART	SIZE	DIA	L1	L2	SSP (INC.VAT)
01278191	CEILING SUPPORT	100/150	150	208	40	£40
01279191	"	130/200	200	260	40	£44



## LOCKING BAND

Used to complete and secure joints.

CODE	PART	SIZE	DIA	SSP (INC.VAT)
0127828	LOCKING BAND	100/150	145 - 160	£9
0127928	"	130/200	195 - 210	£19

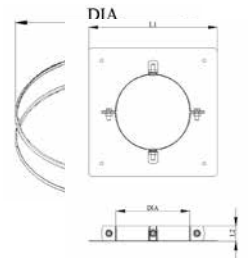

## GUY WIRE BAND

A guy wire bracket can be used to brace a flue system when it protrudes more than 1.5m beyond its last support. It is clamped to the flue body and allows for the fixing of guy wires to ridge stays and slate brackets.

CODE	PART	SIZE	DIA	L1	SSP (INC.VAT)
01278291	GUY WIRE BAND	100/150	150	25	£19
01279291	"	130/200	200	25	£19

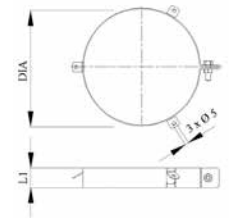

## TERMINALS

For roof and wall termination.

CODE	PART	SIZE	DIA A	DIA B	L1	SSP (INC.VAT)
0127851	ROOF TERMINAL	100/150	100	150	502	£210
0127951	"	130/200	130	200	502	£299

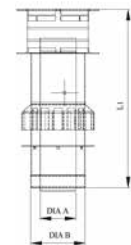

CODE	PART	SIZE	DIA A	DIA B	L1	L2	L3	SSP (INC.VAT)
0127853	WALL TERMINAL	100/150	100	150	480	206	315	£179
0127953	"	130/200	130	200	495	195	400	£349



CODE	PART	SIZE	SSP (INC.VAT)
0128127	TL70SL SPLIT TERMINAL	100/150	£169

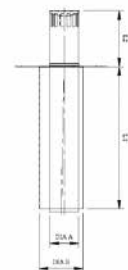

## MEASURING ELEMENT

The measuring element is used for checking the chimney draught, flue temperature & combustion efficiency of the heating appliance.

CODE	PART	SIZE	DIA A	DIA B	SSP (INC.VAT)
0127891	MEASURING ELEMENT	100/150	100	150	£79
0127991	"	130/200	130	200	£99

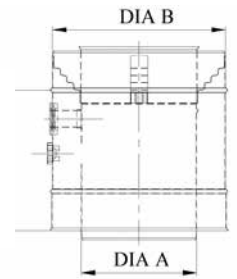

## BALANCED FLUE REDUCING ADAPTOR 130-100

Allows you to reduce your outer flue diameter from 200 to 150 when the flue configuration is vertical only.

CODE	PART	SIZE	SSP (INC.VAT)
0127990	BALANCED FLUE REDUCING ADAPTOR	130-100	£159



## BALANCED FLUE RENOVATION KIT

Designed for existing brick or ceramic chimneys including roof terminal.

CODE	PART	SIZE	SSP (INC.VAT)
0128040	BALANCED FLUE RENOVATION KIT 100MM C/W TERMINAL (BUNDLE)	100/150 - 100MM C/W TERMINAL	£419
0127855	BALANCED FLUE RENOVATION KIT	BALANCED FLUE RENOVATION KIT	£210

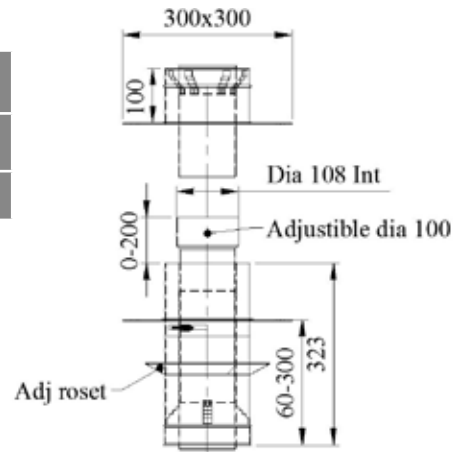

## HORIZONTAL FLUE RENOVATION KIT

Designed for existing brick or ceramic chimneys including roof terminal.

CODE	PART	SIZE	SSP (INC.VAT)
0128194	HORIZONTAL RENOVATION KIT C/W TERMINAL X2 SPACERS X1 ELBOW	100/150 - 100MM C/W TERMINAL	£675

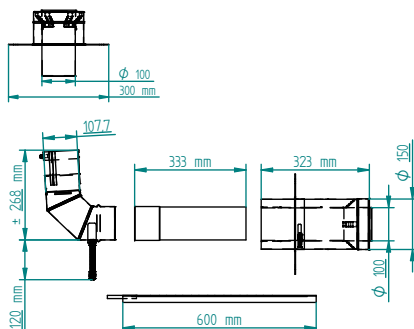

# CONCENTRIC DECO BALANCED FLUE SYSTEM.

New to the Vision Trimline range is the DECO concentric flue system. Elegant connecting pipes with no visible locking bands available in black coated stainless steel. Both the design and ease of installation are of a very high standard. The connection of the various sections and elements is carried out by means of a click connection with the cam spring. Turn the flue to the correct position and when you hear the "click" it is already securely attached. It has never been so easy to quickly install a beautiful connecting pipe!

The DECO system is the first and only system that works with this unique click connection and is made of high-quality stainless steel material and is resistant to high temperatures and flue gases.



Now available, please speak to our sales office or area representative for prices or more information.





# ACCESSORIES.

## GLASS FIBRE WALL COVERING

MICROLITH GS 205 Glass Fibre Fleece. For use when covering any unsightly surfaces, such as concrete, cement, wood panelling, and poor cracked plaster. This is also the tried and tested product for use around hole in the wall fires which due to the extreme heat generated can cause hair line cracking of the surrounding plaster, with GS 205 this problem is resolved permanently.



CODE	DESCRIPTION	SSP (INC.VAT)
1370065	AFS Ready Mixed WallCovering 5KG Adhesive	£27.68
1370066	Microlith WallCovering 25 Metre Roll	£92.28

## GLASS CLEANER

Glass cleaner suitable for all glass throughout Vision Trimline appliances including ARG glass. Pack contains glass cleaner, application cloth and gloves, full instructions included.

CODE	DESCRIPTION	SSP (INC.VAT)
0128087	AR Glass Cleaner 500ml	£24



## GLOWING WOOL

Our stunning gas fireplaces are the most realistic on the market, unrecognisable from a real burning log fire. Add the finishing touches with our innovative LED glowing wool ember technology.

We've managed to perfect even the impression of smouldering embers down to the very last detail. Even on the very lowest burner setting, your fire will still be a joy to watch, with balanced flames and never ending. Glowing wool adds the finishing touch to your fireplace.

It creates a warming environment whilst the embers flicker between the slow & calming flames, ensuring your Vision Trimline appliance has the ultimate flame experience. Smouldering embers, made out of glowing wool.

CODE	DESCRIPTION	SSP (INC.VAT)
0125580	Glowing Wool	£23.99





# TERMS & CONDITIONS

## 1. Prices

Prices charged will be those at the time of delivery as shown in our price list, or as a quotation. We reserve the right to adjust prices without prior notice. Clerical errors are subject to correction (without prior notification). In the case of items manufactured to customers own special requirements, we reserve the right to charge a deposit at the time of placing an order. Carriage paid value may vary from area to area and can be subject to change. Please contact our sales office for updated terms.

## 2. VAT

VAT will be charged at the rate ruling at the time of delivery.

## 3. Payment

Account customers payments are due by the last day of the month following delivery, unless other terms are agreed prior to dispatch. Overdue accounts: we reserve the right to suspend further deliveries until all overdue accounts are paid in full, without prior notice. Overdue accounts: we reserve the right to commence legal recovery proceedings without prior notice. COD accounts: Payment by cheque or cash to our driver on delivery of goods. COD accounts: If cheque is not available on day of delivery it must be posted to arrive at this office within seven days, failure to do so will result in your account being suspended. No more deliveries will be made until full payment is received. We reserve the right to charge interest on all outstanding invoices beyond our terms.

## 4. Delivery

Shortages: all shortages must be reported within 5 days of delivery of goods. Total non-delivery of goods must be reported immediately upon receipt of invoice. Any delivery days quoted are genuine forecasts but shall not be legally binding on the supplier. Timed deliveries cannot be arranged. In the event of the supplier being unable to supply goods subsequent to receiving an order from the buyer, the supplier shall not be liable for any incidental or consequential loss. It is the buyer's responsibility, regardless of delivery address, to ensure the goods are as ordered and they are of satisfactory quality. The supplier strongly recommends that the buyer checks correct description and quality on goods delivery notes. In the event of any discrepancy whatsoever, the buyer must notify the supplier within 5 days of arrival of consignment, as stated on our delivery notes, and before the goods are processed in any way otherwise no responsibility can be accepted for any claims.

Upon acceptance of deliveries the buyer must sign the suppliers or carriers delivery note. Should examination at the time of delivery not be possible, the delivery note must be signed unchecked in order for any subsequent claim to be acceptable for damage in transit. Claims for loss or damage must be made within 5 days of arrival of consignment, informing the supplier and carrier of the loss or damage involved. Damaged items and packaging must be retained for inspection. The supplier shall not be held liable otherwise. Non arrival of goods despatched from the supplier, by van or other method, must be notified to the supplier within "24 hours" from the quoted delivery date, immediately by telephone, fax or email. In all events, the limits of liability for any fault or defect in the product shall be a sum not exceeding the purchase price of the particular goods, and the supplier shall not be liable for any loss howsoever arising. The supplier will not accept any liability for delays caused by "force majeure" beyond the suppliers' control. For next day delivery on replacement glass products, we aim to deliver within 24 working hours (Mon-Fri) on all orders placed before 2pm i.e order Monday 1pm, receive glass Tuesday next day. Highland and Islands will incur higher carriage charges, prices and delivery options should be checked prior to order.

## 5. Claims

All claims must be in writing. Damaged goods: this must be reported as soon as it is known, but no later than 5 days after delivery. Faulty goods: in the case of claim for faulty goods, replacements may be supplied and charged, pending a report from the manufacturer. Please note: wooden mantels and decorative tiles are excluded from our 5 days policy for damaged and faulty goods, these items MUST be checked on receipt.

## 6. Return of goods

We cannot accept the return of goods which have been specially obtained from the manufacturer. In the case of incorrectly ordered goods, if returned, they will be subject to a re-handling charge of at least 20%. No goods will be collected by our transport without prior agreement, nor without our collection note.

## 7. Title & Risk

Until the supplier has been paid in full by the customer for the goods supplied by it and all other balances outstanding to it from the customer at the date such goods are invoiced to the customer have been settled:- Such goods remain the property of the supplier, although the risk therein passes to the customer as soon as the goods are delivered to the customer's premises, and the customer shall indemnify the supplier against any loss or damage thereto. Until such time as property of the goods passes to the customer, the relationship between the supplier and the customer shall be that of bailer and bailee. The customer agrees to store the goods until title to the goods shall have passed to the customer hereunder in such a way that they are readily identifiable as the property of the supplier. Without prejudice to any other remedies, the supplier may repossess those goods at any time from the customer, and for that purpose the supplier, its agents and servants may enter any premises upon which the goods are on, or reasonably thought by the supplier to be situated. The customer has the right to agree to sell and deliver, or dispose of the goods to any sub-purchaser, but any such transaction shall be deemed to be made on behalf of the supplier (but without imposing any liability on the supplier to such sub-purchaser), and the customer shall hold the proceeds thereof, or rights arising therefrom, against the sub-purchaser for and on behalf of the supplier until such time as the customer shall have made full payment for such goods and immediately upon such sale or disposal, the property rights of the supplier hereunder shall pass to the customer on the condition that he ensures the sub-purchaser pays the purchase price into a separate bank account in the name of the customer.

Nothing in these conditions shall confer any right on the customer to return goods supplied by the supplier or refuse or delay payment thereof. In the event of a liquidator or receiver being appointed, we reserve the right to set off any monies owed to this company against any monies owed by this company. We reserve the right to pass on any costs of debt collection which may be incurred by this company. Failure to make payment of our account within our terms may result in the account being suspended, and any goods supplied thereafter will be on a pro-forma basis only.

## 8. Suspension or termination of any contract

If the customer shall in the sole opinion of the supplier be unable or be unlikely to be able to pay any sums he owes the supplier, then the supplier shall (without prejudice to any other rights hereunder) be entitled to demand security prior to delivery, either by payment in cash, or by bank guarantee, notwithstanding any terms previously agreed, and in the event that the customer shall be deemed to have repudiated any contract without liability. If the customer commits any breach of these terms and conditions, or of a contract, or if any distress or execution be levied upon the customer or his property, or if shall make or offer to make any arrangements with creditors or commit any act of bankruptcy, or if any petition receiving order in bankruptcy be presented or made against him, or if a receiver be appointed over all or any of the assets of the customer, or if a winding-up order be made against the customer, or if the customer goes into liquidation (otherwise than for the purpose of reconstruction or amalgamation), the supplier shall without prejudice to any other rights and remedies it might have, and without any liability whatsoever have the right forthwith by notice in writing to:

1. Suspend or terminate any contract, or any unfulfilled part thereof.
2. Stop delivery of any goods.

## 9. Governing Law

Any contract, and these terms and conditions, shall be governed by English law, and any disputes arising in relation to the goods supplied, or the terms of the contract, shall be determined by the English courts to whose jurisdiction and decision the supplier and the customer hereby submit.

## 10. Copy Invoicing

Charges for copy invoices: requests for copy invoices that are more than 90 days old will be liable to an administration fee of £1.00p.

## 11. Guarantee

Guarantee covers replacement faulty goods only, no consideration for consequential loss due to re-decoration or re-installation will be considered.

## 12. Non-internet Policy

The Penman Collection is an exclusive, non-internet range as detailed separately in the supplier/buyer contract.



VISION  
trimline